



AIR HANDLERS

****AHLA- High Efficiency**
featuring R-22 Refrigerant

****AHLL- High Efficiency**
featuring Earth-Friendly
R-410A Refrigerant



****AHSA- Standard Efficiency**
featuring R-22 Refrigerant

****AHSL- Standard Efficiency**
featuring Earth-Friendly
R-410A Refrigerant



Features

- ****AHLA/**AHLL** feature GE's new X-13 motor which provides enhanced SEER performance with most WeatherKing outdoor units.
- 1 1/2 ton [5.3 kW] through 5 ton [17.6 kW] models are between 42 1/2 to 55 1/2 inches [1080 to 1410 mm] tall and 22 inches [559 mm] deep.
- Versatile 4-way convertible design for upflow, downflow, horizontal left and horizontal right applications.
- Factory-installed high efficiency indoor coil.
- All models meet or exceed 330 to 400 CFM [156 to 189 L/s] per ton at .3 inches [.7 kPa] of external static pressure.
- Enhanced airflow up to .7" external static pressure.
- Sturdy construction with 1.0 inch [.24 kPa] of reinforced foil faced jacket insulation for excellent thermal and sound insulation.
- Field-installed auxiliary electric heater kits provide exact heat for indoor comfort. Kits include circuit breakers which meet UL and cUL requirements for service disconnect.



Engineering Features

AHLA/AHLL/**AHSA/**AHSL- Series

- The most compact unit design available, all standard heat air handler models only 42¹/₂ to 55¹/₂ inches [1079 to 1409 mm] high.
- Attractive pre-painted cabinet exterior.
- Rugged wall steel cabinet construction, designed for added strength and versatility.
- 1.0" foil faced insulation mechanically retained in blower compartment for excellent thermal and sound performance.
- Four leg blower motor mount.
- Blower housing with controls, motor and blower. Slide out design for service and maintenance convenience.
- Traditional open wire element design for heat applications.
- Field convertible for vertical downflow, horizontal left hand or right hand air supply.
- 3 combustible floor base accessories fit all model sizes when required for downflow installations on combustible floors.
- Indoor coil design provides low air side pressure drop, high performance and extremely compact size.
- Expansion valve on indoor coil provides for operation with air conditioning or heat pump using the same coil.
- Coils are constructed of aluminum fins bonded to internally grooved copper tubing.
- Molded polymer corrosion resistant condensate drain pan is provided on all indoor coils.
- Supply duct flanges provided as standard on air handler cabinet.
- Provisions for field electrical, connections available from either side or top of the air handler cabinet.
- Connection point for high voltage wiring is inside the air handler cabinet. Low voltage connection is made on the outside of the air handler cabinet.
- Concentric knockouts are provided for power connection to cabinet. Installer may pull desired hole size up to 2 inches [51 mm] for 1¹/₂ inch [38 mm] conduit.
- Front refrigerant and drain connections.

[] Designates Metric Conversions



GENERAL TERMS OF LIMITED WARRANTY

ICECOSM will furnish a replacement for any part of this product which fails in normal use and service within the applicable periods stated, in accordance with the terms of the limited warranty.

Indoor Coil leaks caused by	
factory defects	Five (5) Years
Electric Heating Element	Five (5) Years
Any Other Part	Five (5) Years

For Complete Details of the Limited Warranty, Including Applicable Terms and Conditions, See Your Local Installer or visit www.ICECOhvac.com.

Model Identification

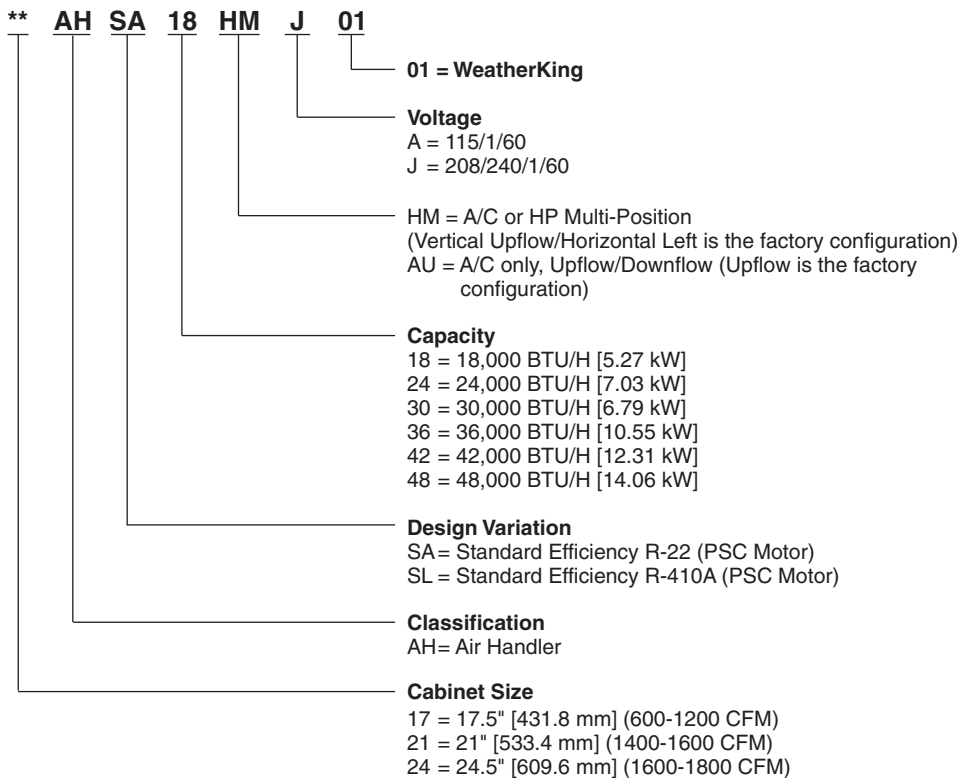
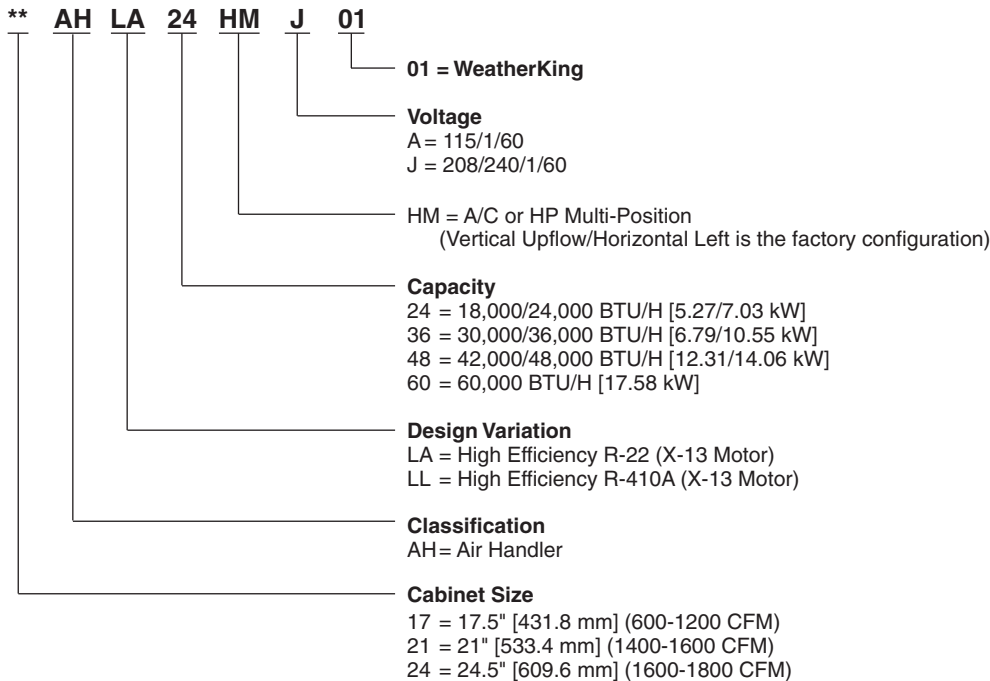

[] Designates Metric Conversions

Available Models at A Voltage	
17AHLA24HMA01	17AHS24HMA01
17AHLA36HMA01	17AHS36HMA01
21AHLA48HMA01	17AHS36HMA01
24AHLA48HMA01	21AHS42HMA01
24AHLA60HMA01	21AHS48HMA01
17AHL24HMA01	17AHS18AUA01
17AHL36HMA01	17AHS24AUA01
21AHL48HMA01	17AHS30AUA01
24AHL48HMA01	17AHS36AUA01
24AHL60HMA01	21AHS42AUA01
17AHS18HMA01	21AHS48AUA01
17AHS24HMA01	17AHS18AUA01
17AHS30HMA01	17AHS24AUA01
17AHS36HMA01	17AHS30AUA01
21AHS42HMA01	17AHS36AUA01
21AHS48HMA01	21AHS42AUA01
17AHS18HMA01	21AHS48AUA01

Available Models at J Voltage	
17AHL24HJM01	17AHS36HJM01
17AHLA36HJM01	21AHS36HJM01
21AHLA48HJM01	21AHS42HJM01
24AHLA48HJM01	21AHS48HJM01
24AHLA60HJM01	24AHS48HJM01
17AHL24HJM01	17AHS18AUJ01
17AHL36HJM01	17AHS24AUJ01
21AHL48HJM01	17AHS30AUJ01
24AHL48HJM01	17AHS36AUJ01
24AHL60HJM01	21AHS42AUJ01
17AHS18HJM01	21AHS48AUJ01
17AHS24HJM01	21AHS18AUJ01
17AHS30HJM01	24AHS48AUJ01
17AHS36HJM01	17AHS18AUJ01
21AHS42HJM01	17AHS24AUJ01
21AHS48HJM01	17AHS30AUJ01
24AHS48HJM01	17AHS36AUJ01
17AHS18HJM01	21AHS42AUJ01
17AHS24HJM01	21AHS48AUJ01
17AHS30HJM01	24AHS48AUJ01

- Supply circuit protective devices may be fuses or "HACR" type circuit breakers.
- Largest motor load is included in single circuit and multiple circuit.
- If non-standard fuse size is specified, use the next larger fuse size.
- J Voltage (230V) single-phase air handler is designed to be used with single or three phase 230 volt power. In the case of connecting 3-phase power to the air handler terminal block, bring only two leads to the terminal block. Cap, insulate and fully secure the third lead.
- The air handlers are shipped from the factory with the proper indoor coil installed, and cannot be ordered without a coil.
- The air handlers do not have an internal filter rack. An external filter rack or other means of filtration is required.

Unit Dimensions

ELECTRICAL CONNECTIONS
MAY EXIT TOP OR EITHER SIDE

HIGH VOLTAGE CONNECTION $\frac{7}{8}$ " [22.2 mm],
 $\frac{1}{2}$ " [12.7 mm], $\frac{3}{4}$ " [19.1 mm] DIA. KNOCKOUTS.

LOW VOLTAGE CONNECTION
 $\frac{5}{8}$ " [15.9 mm] AND $\frac{7}{8}$ " [22.2 mm] KNOCKOUT

AUXILIARY DRAIN CONNECTION
 $\frac{3}{4}$ " [19.1 mm] FEMALE PIPE THREAD (NPT)
HORIZONTAL APPLICATION ONLY

PRIMARY DRAIN CONNECTION
 $\frac{3}{4}$ " [19.1 mm] FEMALE PIPE THREAD (NPT)

AUXILIARY DRAIN CONNECTION
 $\frac{3}{4}$ " [19.1 mm] FEMALE PIPE THREAD (NPT)
UPFLOW/DOWNFLOW APPLICATION ONLY

LIQUID LINE CONNECTION
COPPER (SWEAT)

VAPOR LINE CONNECTION
COPPER (SWEAT)

SUPPLY AIR ↑

NOTE: 24" CLEARANCE REQUIRED IN FRONT OF
UNIT FOR FILTER AND COIL MAINTENANCE.

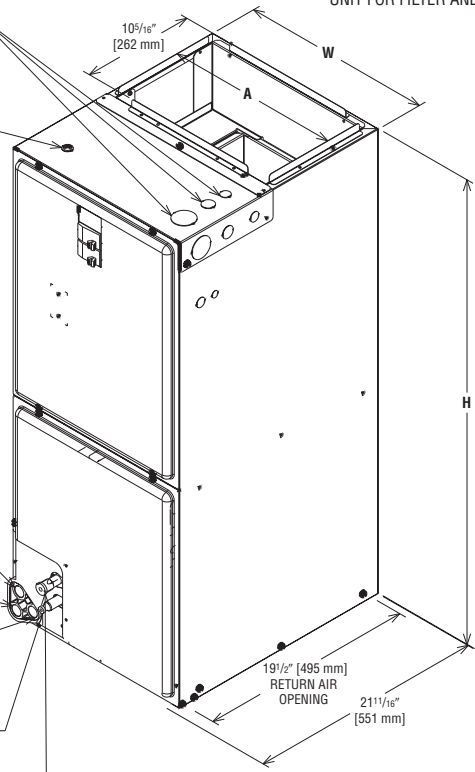

UPFLOW UNIT SHOWN:
UNIT MAY BE INSTALLED UPFLOW, DOWNFLOW,
HORIZONTAL RIGHT OR LEFT AIR SUPPLY.

Return Air Opening Dimensions

Model Cabinet Size	Return Air Opening Width (Inches)	Return Air Opening Depth/Length (Inches)
17	15 ⁷ / ₈	19 ³ / ₄
21	19 ³ / ₈	19 ³ / ₄
24	22 ⁷ / ₈	19 ³ / ₄

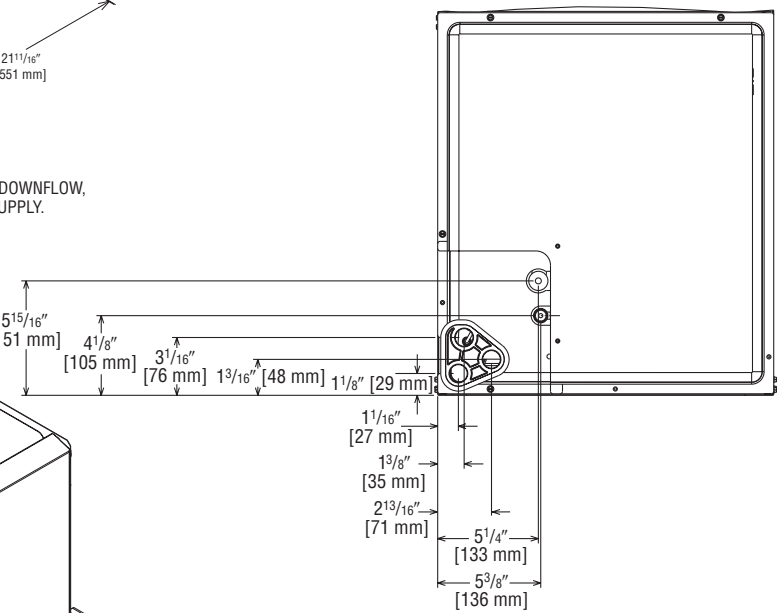
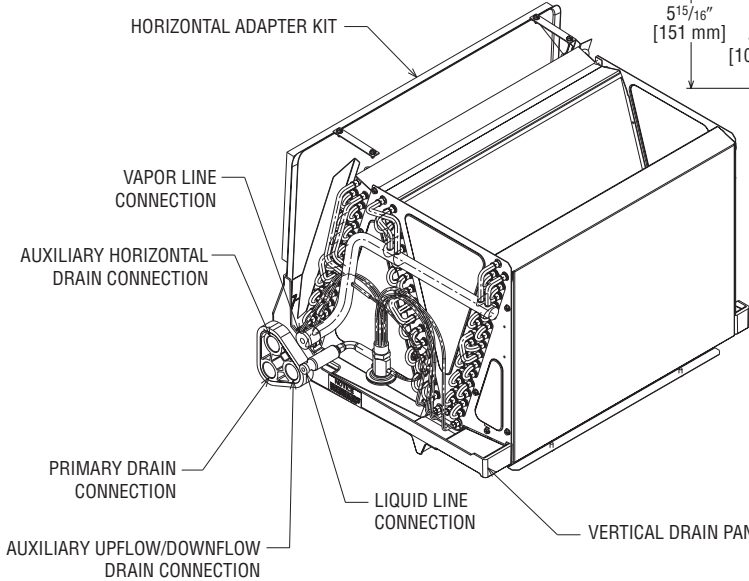

[] Designates Metric Conversions
() Designates Unit with Double Coil Cabinet

Unit Dimensions & Weights

Model Size	Unit Width "W" In. [mm]	Unit Height "H" In. [mm]	Supply Duct "A" In. [mm]	Air Flow CFM (Nom.) [L/s]		Unit Weight/Shipping Weight (Lbs.) [kg]
				Lo	Hi	
1817/2417	17 ¹ / ₂ [445]	42 ¹ / ₂ [1080]	16 [406]	600 [283]	800 [378]	82/96 [37/44]
3017/3617	17 ¹ / ₂ [445]	42 ¹ / ₂ [1080]	16 [406]	1000 [472]	1200 [566]	92/106 [37/48]
3621	21 [533]	42 ¹ / ₂ [1080]	19 ¹ / ₂ [495]	1200 [566]	—	97/112 [44/51]
4221/4821	21 [533]	50 ¹ / ₂ [1282]	19 ¹ / ₂ [495]	1400 [661]	1600 [755]	150/166 [68/75]
4824	24 ¹ / ₂ [622]	55 ¹ / ₂ [1410]	23 [584]	1600 [755]	—	162/180 [73/81]
6024	24 ¹ / ₂ [622]	55 ¹ / ₂ [1410]	23 [584]	—	1800 [850]	181/198 [82/90]

Airflow Directions

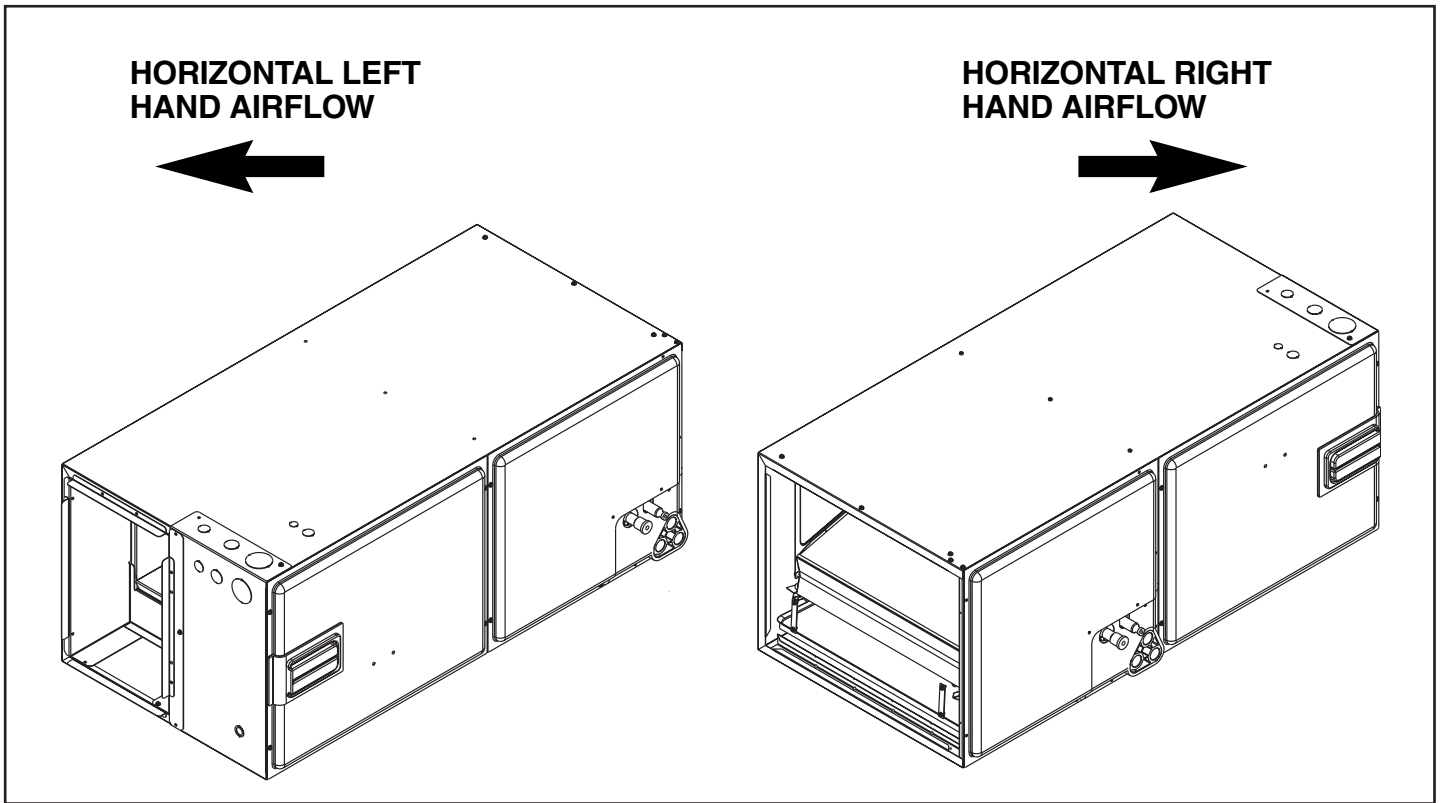
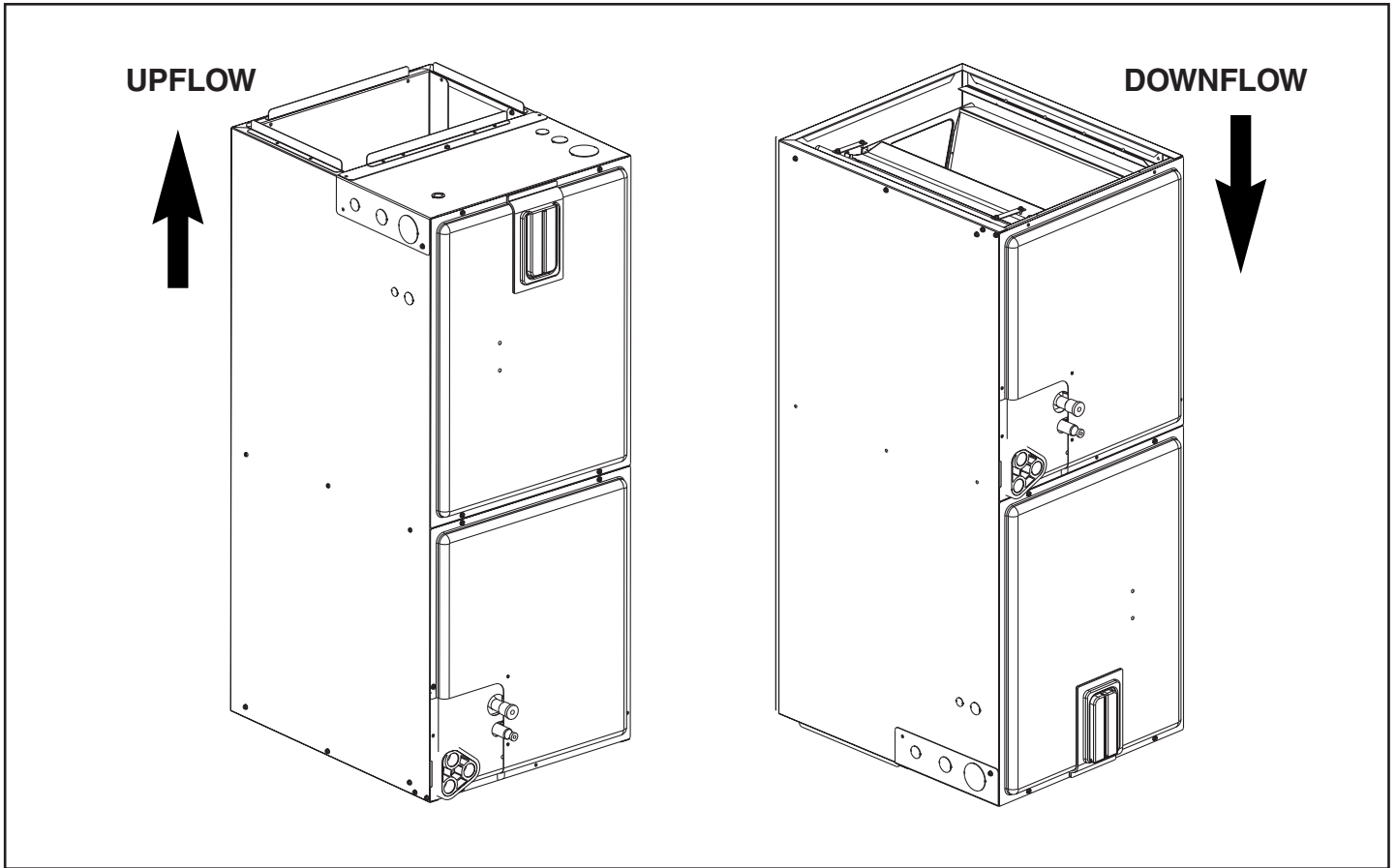

Airflow Performance

Airflow performance data is based on cooling performance with a coil and no filter in place. Select performance table for appropriate unit size, voltage and number of electric heaters to be used. Make sure external static applied to unit allows operation within the minimum and maximum limits shown in table

below for both cooling and electric heat operation. For optimum blower performance, operate the unit in the .3 [8 mm] to .7 inches [18 mm] W.C. external static range. Units with coils should be applied with a minimum of .1 inch [3 mm] W.C. external static range.

Airflow Operating Limits

Model Cabinet Size	17		17		21		24	
Cooling BTUH x 1,000 Cooling Tons Nominal	-018 1.5	-024 2	-030 2.5	-036 3	-042 3.5	-048 4	-048 4	-060 5
Heat Pump or Air Conditioning Maximum Heat/Cool CFM [L/s] (37.5 CFM [18 L/s]/1,000 BTUH) (450 CFM [212 L/s]/Ton Nominal)	675 [319]	900 [425]	1125 [531]	1350 [637]	1575 [743]	1800 [850]	1800 [850]	1930 [911]
Heat Pump or Air Conditioning Nominal Heat/Cool CFM [L/s] (33.3 CFM [16 L/s]/1,000 BTUH) (400 CFM [189 L/s]/Ton Nominal)	600 [283]	800 [378]	1000 [472]	1200 [566]	1400 [661]	1600 [755]	1600 [755]	1800 [850]
Heat Pump or Air Conditioning Minimum Heat/Cool CFM [L/s] (30.0 CFM [14 L/s]/1,255 BTUH) (360 CFM [170 L/s]/Ton Nominal)	540 [255]	720 [340]	900 [425]	1080 [510]	1260 [595]	1440 [680]	1440 [680]	1620 [765]
Maximum kW Electric Heating & Minimum Electric Heat CFM [L/s]	10 500 [236]	10 650 [307]	15 865 [408]	15 1015 [400]	20 1200 [566]	20 1400 [600]	20 1400 [600]	25 1730 [821]
Maximum Electric Heat Rise °F [°C]	85 [29]	85 [29]	85 [29]	85 [29]	85 [29]	85 [29]	85 [29]	85 [29]

[] Designates Metric Conversions

240V Airflow Performance Data—**AHSA/**AHSL (PSC Motor)

Model No.	Motor Speed from Factory	Manufacturer Recommended Air-Flow Range (Min/Max) CFM	Blower Size/ Motor HP [W] # of Speed	Motor Speed	PSC CFM [L/s] Air Delivery/RPM/Watts—240 Volts							
					External Static Pressure—Inches W.C. [kPa]							
					0.1 [.02]	0.2 [.05]	0.3 [.07]	0.4 [.10]	0.5 [.12]	0.6 [.15]	0.7 [.17]	
-1817 No Heater	High 240V	517/711 CFM [244/336 L/s]	10x6 1/5 HP [149] 2 Speed	Low	CFM	668 [315]	637 [301]	595 [281]	560 [264]	517 [244]	—	—
					RPM	541	596	657	706	761	—	—
					Watts	180	171	166	161	109	—	—
				High	CFM	—	—	—	—	711 [336]	662 [312]	614 [290]
					RPM	—	—	—	—	812	853	890
					Watts	—	—	—	—	243	227	210
-1817 with 13 kW Heater	High 240V	487/661 CFM [230/312 L/s]	10x6 1/5 HP [149] 2 Speed	Low	CFM	638 [301]	607 [286]	565 [267]	530 [250]	487 [230]	—	—
					RPM	571	626	687	736	791	—	—
					Watts	171	162	157	152	146	—	—
				High	CFM	—	—	—	—	661 [312]	612 [289]	564 [266]
					RPM	—	—	—	—	837	878	915
					Watts	—	—	—	—	232	216	199
-2417 No Heater	High 240V	647/888 CFM [305/419 L/s]	10x6 1/5 HP [149] 2 Speed	Low	CFM	817 [386]	779 [368]	757 [357]	693 [327]	647 [305]	—	—
					RPM	616	667	715	770	808	—	—
					Watts	239	230	221	206	205	—	—
				High	CFM	—	—	—	—	888 [419]	828 [391]	774 [365]
					RPM	—	—	—	—	875	908	958
					Watts	—	—	—	—	331	313	301
-2417 with 13 kW Heater	High 240V	617/838 CFM [291/395 L/s]	10x6 1/5 HP [149] 2 Speed	Low	CFM	787 [371]	749 [353]	727 [343]	663 [313]	617 [291]	—	—
					RPM	646	697	745	800	838	—	—
					Watts	230	221	212	197	187	—	—
				High	CFM	—	—	—	—	838 [395]	778 [367]	724 [342]
					RPM	—	—	—	—	900	933	983
					Watts	—	—	—	—	320	302	290
-3017 No Heater	High 240V	864/1004 CFM [408/474 L/s]	10x8 1/4 HP [186] 2 Speed	Low	CFM	1022 [482]	987 [466]	940 [444]	903 [426]	864 [408]	—	—
					RPM	700	754	794	633	870	—	—
					Watts	344	313	302	309	288	—	—
				High	CFM	—	—	—	—	1004 [474]	951 [449]	883 [417]
					RPM	—	—	—	—	924	953	975
					Watts	—	—	—	—	364	352	344
-3017 with 18 kW Heater	High 240V	814/904 CFM [384/427 L/s]	10x8 1/4 HP [186] 2 Speed	Low	CFM	972 [459]	937 [442]	890 [420]	853 [403]	814 [384]	—	—
					RPM	750	804	844	883	920	—	—
					Watts	324	293	282	274	268	—	—
				High	CFM	—	—	—	—	904 [427]	851 [402]	783 [370]
					RPM	—	—	—	—	949	978	1000
					Watts	—	—	—	—	334	322	314
-3617/-3621 No Heater	High 240V	1104/1248 CFM [521/589 L/s]	10x8 1/3 HP [249] 2 Speed	Low	CFM	1229 [580]	1201 [567]	1170 [552]	1141 [538]	1104 [521]	—	—
					RPM	788	833	872	909	951	—	—
					Watts	466	462	427	406	395	—	—
				High	CFM	—	—	—	—	1248 [589]	1194 [563]	1133 [535]
					RPM	—	—	—	—	1008	1028	1042
					Watts	—	—	—	—	488	475	454

- Notes:
- All 208/240V PSC motors have voltage taps for 208 and 240 volts.
 - All 208/240V PSC motors are shipped on high speed and 240 volts.
 - If the application external static is less than 0.5" WC, adjust the motor speed to the low static speed as described below:
 - Unplug the black motor wire off the relay on the control board and plug in the red motor wire.
 - Replace the cap on the black motor wire.
 - Voltage change (208/240V motors):
 - Move the orange lead to transformer 208V tap from 240V tap. Replace the wire cap on 240V tap.
 - Unplug the purple motor wire off the transformer and plug in the yellow motor wire.
 - Replace the cap on the purple motor wire.
 - The above airflow table lists the airflow information for air handlers without heater and air handler with maximum heater allowed for each model.
 - The following formula can be used to calculate the approximate airflow, if a smaller (N kW) than the maximum heater kit is installed.
 Approximate Airflow = Airflow without heater - (Airflow without heater - Airflow with maximum heater) x (N kW/maximum heater kW)

[] Designates Metric Conversions

240V Airflow Performance Data—**AHSA/**AHSL (PSC Motor) (con't.)

Model No.	Motor Speed from Factory	Manufacturer Recommended Air-Flow Range (Min/Max) CFM	Blower Size/ Motor HP [W] # of Speed	Motor Speed	PSC CFM [L/s] Air Delivery/RPM/Watts—240 Volts							
					External Static Pressure—Inches W.C. [kPa]							
					0.1 [.02]	0.2 [.05]	0.3 [.07]	0.4 [.10]	0.5 [.12]	0.6 [.15]	0.7 [.17]	
-3617/3621 with 18 kW Heater	High 240V	1054/1148 CFM [497/542 L/s]	10x8 1/3 HP [249] 2 Speed	Low	CFM	1179 [556]	1151 [543]	1120 [529]	1091 [515]	1054 [497]	—	—
					RPM	838	883	922	959	1001	—	—
					Watts	446	442	407	386	375	—	—
				High	CFM	—	—	—	—	1148 [542]	1094 [516]	1033 [487]
					RPM	—	—	—	—	1033	1053	1067
					Watts	—	—	—	—	458	445	424
-4221 No Heater	High 240V	1241/1537 CFM [586/725 L/s]	10x10 1/2 HP [373] 2 Speed	Low	CFM	1526 [720]	1474 [696]	1427 [673]	1307 [617]	1241 [586]	—	—
					RPM	834	870	902	948	968	—	—
					Watts	560	549	535	476	462	—	—
				High	CFM	—	—	—	—	1537 [725]	1418 [669]	1334 [630]
					RPM	—	—	—	—	1072	1077	1085
					Watts	—	—	—	—	860	835	820
-4221 with 20 kW Heater	High 240V	1225/1500 CFM [553/678 L/s]	10x10 1/2 HP [373] 2 Speed	Low	CFM	1456 [687]	1404 [663]	1357 [640]	1237 [584]	1171 [553]	—	—
					RPM	886	906	925	959	992	—	—
					Watts	542	524	505	468	431	—	—
				High	CFM	—	—	—	—	1437 [678]	1318 [622]	1234 [582]
					RPM	—	—	—	—	1080	1090	1105
					Watts	—	—	—	—	840	800	785
-4821/-4824 No Heater	High 240V	1572/1824 CFM [742/861 L/s]	10x10 3/4 HP [559] 2 Speed	Low	CFM	1741 [822]	1719 [811]	1667 [787]	1628 [768]	1572 [742]	—	—
					RPM	878	920	950	981	1007	—	—
					Watts	785	757	707	667	641	—	—
				High	CFM	—	—	—	—	1824 [861]	1767 [834]	1653 [780]
					RPM	—	—	—	—	1102	1112	1121
					Watts	—	—	—	—	871	830	770
-4821/-4824 with 25 kW Heater	High 240V	1225/1500 CFM [709/814 L/s]	10x10 3/4 HP [559] 2 Speed	Low	CFM	1671 [789]	1649 [778]	1597 [754]	1558 [735]	1502 [709]	—	—
					RPM	945	965	995	1025	1050	—	—
					Watts	715	685	650	630	610	—	—
				High	CFM	—	—	—	—	1724 [814]	1667 [787]	1553 [733]
					RPM	—	—	—	—	1116	1119	1130
					Watts	—	—	—	—	810	780	730

- Notes:
- All 208/240V PSC motors have voltage taps for 208 and 240 volts.
 - All 208/240V PSC motors are shipped on high speed and 240 volts.
 - If the application external static is less than 0.5" WC, adjust the motor speed to the low static speed as described below:
 - Unplug the black motor wire off the relay on the control board and plug in the red motor wire.
 - Replace the cap on the black motor wire.
 - Voltage change (208/240V motors):
 - Move the orange lead to transformer 208V tap from 240V tap. Replace the wire cap on 240V tap.
 - Unplug the purple motor wire off the transformer and plug in the yellow motor wire.
 - Replace the cap on the purple motor wire.
 - The above airflow table lists the airflow information for air handlers without heater and air handler with maximum heater allowed for each model.
 - The following formula can be used to calculate the approximate airflow, if a smaller (N kW) than the maximum heater kit is installed.

$$\text{Approximate Airflow} = \text{Airflow without heater} - (\text{Airflow without heater} - \text{Airflow with maximum heater}) \times (\text{N kW}/\text{maximum heater kW})$$

[] Designates Metric Conversions

115/208/480V Airflow Performance Data—**AHSA/**AHSL (PSC Motor)

Model No.	Motor Speed from Factory	Manufacturer Recommended Air-Flow Range (Min/Max) CFM	Blower Size/ Motor HP [W] # of Speed	Motor Speed	PSC CFM [L/s] Air Delivery/RPM/Watts—115/208/480 Volts							
					External Static Pressure—Inches W.C. [kPa]							
					0.1 [.02]	0.2 [.05]	0.3 [.07]	0.4 [.10]	0.5 [.12]	0.6 [.15]	0.7 [.17]	
-1817 No Heater	High	523/705 CFM [247/333 L/s]	10x6 1/5 HP [149] 2 Speed	Low	CFM	681 [321]	636 [300]	606 [286]	567 [268]	523 [247]	—	—
					RPM	541	601	670	714	768	—	—
					Watts	193	181	173	164	157	—	—
				High	CFM	—	—	—	—	705 [333]	650 [307]	599 [283]
					RPM	—	—	—	—	815	861	989
					Watts	—	—	—	—	239	227	204
-1817 with 13 kW Heater	High	487/661 CFM [230/312 L/s]	10x6 1/5 HP [149] 2 Speed	Low	CFM	651 [307]	606 [286]	576 [272]	537 [253]	493 [233]	—	—
					RPM	571	631	700	744	798	—	—
					Watts	184	172	164	155	148	—	—
				High	CFM	—	—	—	—	655 [309]	600 [283]	549 [259]
					RPM	—	—	—	—	840	886	1014
					Watts	—	—	—	—	228	216	193
-2417 No Heater	High	647/888 CFM [305/419 L/s]	10x6 1/5 HP [149] 2 Speed	Low	CFM	875 [413]	806 [380]	787 [371]	739 [349]	682 [322]	—	—
					RPM	648	700	745	794	827	—	—
					Watts	259	255	243	234	227	—	—
				High	CFM	—	—	—	—	897 [423]	851 [402]	765 [361]
					RPM	—	—	—	—	906	925	955
					Watts	—	—	—	—	332	318	306
-2417 with 18 kW Heater	High	617/838 CFM [291/395 L/s]	10x6 1/5 HP [149] 2 Speed	Low	CFM	845 [399]	776 [366]	757 [357]	709 [335]	652 [308]	—	—
					RPM	678	730	775	824	857	—	—
					Watts	250	246	234	225	218	—	—
				High	CFM	—	—	—	—	847 [400]	801 [378]	715 [337]
					RPM	—	—	—	—	931	950	980
					Watts	—	—	—	—	321	307	295
-3017 No Heater	High	864/1004 CFM [408/474 L/s]	10x8 1/4 HP [186] 2 Speed	Low	CFM	1038 [490]	1010 [477]	976 [461]	925 [437]	883 [417]	—	—
					RPM	721	771	799	848	880	—	—
					Watts	325	314	303	290	286	—	—
				High	CFM	—	—	—	—	1015 [479]	963 [454]	890 [420]
					RPM	—	—	—	—	928	955	974
					Watts	—	—	—	—	356	341	329
-3017 with 18 kW Heater	High	814/904 CFM [384/427 L/s]	10x8 1/4 HP [186] 2 Speed	Low	CFM	988 [466]	960 [453]	926 [437]	875 [413]	833 [393]	—	—
					RPM	771	821	849	898	930	—	—
					Watts	305	294	283	270	266	—	—
				High	CFM	—	—	—	—	915 [432]	863 [407]	790 [373]
					RPM	—	—	—	—	953	980	999
					Watts	—	—	—	—	326	311	299
-3617/-3621 No Heater	High	1104/1248 CFM [521/589 L/s]	10x8 1/3 HP [249] 2 Speed	Low	CFM	1201 [567]	1170 [552]	1141 [538]	1104 [521]	1062 [501]	—	—
					RPM	833	872	909	951	965	—	—
					Watts	462	427	406	396	385	—	—
				High	CFM	—	—	—	—	1194 [563]	1134 [535]	1078 [509]
					RPM	—	—	—	—	1024	1042	1060
					Watts	—	—	—	—	475	454	417

- Notes:
- All 208/240V PSC motors have voltage taps for 208 and 240 volts.
 - All 208/240V PSC motors are shipped on high speed and 240 volts.
 - All 115V PSC motors are shipped on high speed.
 - If the application external static is less than 0.5" WC, adjust the motor speed to the low static speed as described below:
 - Unplug the black motor wire off the relay on the control board and plug in the red motor wire.
 - Replace the cap on the black motor wire.
 - Voltage change (208/240V motors):
 - Move the orange lead to transformer 208V tap from 240V tap. Replace the wire cap on 240V tap.
 - Unplug the purple motor wire off the transformer and plug in the yellow motor wire.
 - Replace the cap on the purple motor wire.
 - All 480V PSC motors are shipped on high speed.
 - If the application external static is less than 0.5" WC, adjust the motor speed to the low static speed as described below for 3-ton through 4-ton air handlers.

- Unplug the black motor wire off the relay and remove the cap from the red motor wire.
- Plug the red motor wire to the relay and connect the black motor wire with the yellow motor wire.
- For 5-ton air handler, unplug the black motor wire off the relay and plug in the red motor wire, then cap the black motor wire. There is no yellow motor wire on 5-ton air handler.

WARNING: Do not connect red motor wire with yellow motor wire in any circumstance on 480V PSC motors. Connecting red motor wire with yellow motor wire will result in permanent motor damage.

- The above airflow table lists the airflow information for air handlers without heater and air handler with maximum heater allowed for each model.
- The following formula can be used to calculate the approximate airflow, if a smaller (N kW) than the maximum heater kit is installed. Approximate Airflow = Airflow without heater - (Airflow without heater - Airflow with maximum heater) x (N kW/maximum heater kW)

[] Designates Metric Conversions

115/208/480V Airflow Performance Data—**AHSA/**AHSL (PSC Motor)

Model No.	Motor Speed from Factory	Manufacturer Recommended Air-Flow Range (Min/Max) CFM	Blower Size/ Motor HP [W] # of Speed	Motor Speed	PSC CFM [L/s] Air Delivery/RPM/Watts—115/208/480V Volts							
					External Static Pressure—Inches W.C. [kPa]							
					0.1 [.02]	0.2 [.05]	0.3 [.07]	0.4 [.10]	0.5 [.12]	0.6 [.15]	0.7 [.17]	
-3617/3621 with 18 kW Heater	High	1054/1148 CFM [497/542 L/s]	10x8 1/3 HP [249] 2 Speed	Low	CFM	1151 [543]	1120 [529]	1091 [515]	1054 [497]	1012 [478]	-	-
					RPM	883	922	959	1001	1015	—	—
					Watts	442	407	386	376	365	—	—
				High	CFM	—	—	—	—	1094 [516]	1034 [488]	978 [462]
					RPM	—	—	—	—	1049	1067	1085
					Watts	—	—	—	—	445	424	387
-4221 No Heater	High	1241/1537 CFM [580/725 L/s]	10x10 1/2 HP [373] 2 Speed	Low	CFM	1493 [705]	1449 [684]	1363 [643]	1287 [607]	1211 [571]	—	—
					RPM	822	858	885	931	958	—	—
					Watts	540	519	506	484	459	—	—
				High	CFM	—	—	—	—	1514 [714]	1411 [666]	1315 [621]
					RPM	—	—	—	—	1061	1069	1078
					Watts	—	—	—	—	710	702	677
-4221 with 20 kW Heater	High	1225/1500 CFM [538/667 L/s]	10x10 1/2 HP [373] 2 Speed	Low	CFM	1423 [672]	1379 [651]	1293 [610]	1217 [574]	1141 [538]	—	—
					RPM	870	882	925	957	992	—	—
					Watts	514	508	490	461	431	—	—
				High	CFM	—	—	—	—	1414 [667]	1311 [619]	1215 [573]
					RPM	—	—	—	—	1067	1080	1094
					Watts	—	—	—	—	700	678	665
-4821/-4824 No Heater	High	1512/1824 CFM [742/801 L/s]	10x10 3/4 HP [559] 2 Speed	Low	CFM	1711 [807]	1689 [797]	1637 [773]	1598 [754]	1542 [728]	—	—
					RPM	863	905	935	966	992	—	—
					Watts	765	737	687	647	621	—	—
				High	CFM	—	—	—	—	1787 [843]	1679 [792]	1575 [743]
					RPM	—	—	—	—	1089	1098	1110
					Watts	—	—	—	—	695	665	630
-4821/-4824 with 25 kW Heater	High	1225/1500 CFM [695/796 L/s]	10x10 3/4 HP [559] 2 Speed	Low	CFM	1641 [774]	1619 [764]	1567 [739]	1528 [721]	1472 [695]	—	—
					RPM	930	950	985	1015	1041	—	—
					Watts	700	660	630	600	580	—	—
				High	CFM	—	—	—	—	1687 [796]	1579 [745]	1475 [696]
					RPM	—	—	—	—	1095	1107	1120
					Watts	—	—	—	—	670	635	615

- Notes:
- All 208/240V PSC motors have voltage taps for 208 and 240 volts.
 - All 208/240V PSC motors are shipped on high speed and 240 volts.
 - All 115V PSC motors are shipped on high speed.
 - If the application external static is less than 0.5" WC, adjust the motor speed to the low static speed as described below:
 - Unplug the black motor wire off the relay on the control board and plug in the red motor wire.
 - Replace the cap on the black motor wire.
 - Voltage change (208/240V motors):
 - Move the orange lead to transformer 208V tap from 240V tap. Replace the wire cap on 240V tap.
 - Unplug the purple motor wire off the transformer and plug in the yellow motor wire.
 - Replace the cap on the purple motor wire.
 - All 480V PSC motors are shipped on high speed.
 - If the application external static is less than 0.5" WC, adjust the motor speed to the low static speed as described below for 3-ton through 4-ton air handlers.

- Unplug the black motor wire off the relay and remove the cap from the red motor wire.
- Plug the red motor wire to the relay and connect the black motor wire with the yellow motor wire.
- For 5-ton air handler, unplug the black motor wire off the relay and plug in the red motor wire, then cap the black motor wire. There is no yellow motor wire on 5-ton air handler.

WARNING: Do not connect red motor wire with yellow motor wire in any circumstance on 480V PSC motors. Connecting red motor wire with yellow motor wire will result in permanent motor damage.

- The above airflow table lists the airflow information for air handlers without heater and air handler with maximum heater allowed for each model.
- The following formula can be used to calculate the approximate airflow, if a smaller (N kW) than the maximum heater kit is installed. Approximate Airflow = Airflow without heater - (Airflow without heater - Airflow with maximum heater) x (N kW/maximum heater kW)

[] Designates Metric Conversions

115V/208V/240V Airflow Performance Data—**AHLA/**AHL (X-13 Motor)

Model No.	Tonnage Application	Motor Speed From Factory	Manufacturer Recommended Air-Flow Range (Min/Max) CFM	Blower Size/ Motor HP [W] # of Speed	Motor Speed	X-13 CFM [L/s] Air Delivery/RPM/Watts—115/208/240 Volts							
						External Static Pressure—Inches W.C. [kPa]							
						0.1 [.02]	0.2 [.05]	0.3 [.07]	0.4 [.10]	0.5 [.12]	0.6 [.15]	0.7 [.17]	
-2417 No Heater	1.5 Ton	5	509/681 CFM [240/321 L/s]	10x6 1/3 HP [249] 5 Speed	2	CFM	689 [325]	644 [304]	602 [284]	563 [266]	509 [240]	—	—
						RPM	580	633	683	728	781	—	—
						Watts	66	84	86	88	91	—	—
					3	CFM	—	—	—	—	681 [321]	644 [304]	603 [285]
						RPM	—	—	—	—	835	879	916
						Watts	—	—	—	—	136	143	152
-2417 with 13 kW Heater	1.5 Ton	5	490/666 CFM [231/314 L/s]	10x6 1/3 HP [249] 5 Speed	2	CFM	670 [316]	625 [295]	583 [275]	544 [257]	490 [231]	—	—
						RPM	608	661	711	756	809	—	—
						Watts	75	93	95	47	100	—	—
					3	CFM	—	—	—	—	666 [314]	629 [297]	588 [277]
						RPM	—	—	—	—	855	899	936
						Watts	—	—	—	—	144	151	160
-2417 No Heater	2 Ton	5	730/651 CFM [345/307 L/s]	10x6 1/3 HP [249] 5 Speed	4	CFM	875 [413]	839 [396]	804 [379]	762 [360]	730 [345]	—	—
						RPM	679	724	765	810	852	—	—
						Watts	121	131	135	142	143	—	—
					5	CFM	—	—	—	—	862 [407]	828 [391]	801 [378]
						RPM	—	—	—	—	904	940	970
						Watts	—	—	—	—	203	215	228
-2417 with 13 kW Heater	2 Ton	5	711/626CFM [336/295 L/s]	10x6 1/3 HP [249] 5 Speed	4	CFM	856 [404]	820 [387]	785 [370]	743 [351]	711 [336]	—	—
						RPM	707	752	793	838	880	—	—
						Watts	130	140	144	151	152	—	—
					5	CFM	—	—	—	—	837 [395]	803 [379]	776 [366]
						RPM	—	—	—	—	924	960	990
						Watts	—	—	—	—	211	223	288
-3617 No Heater	2.5 Ton	5	935/1084 CFM [441/512 L/s]	10x8 1/2 HP [373] 5 Speed	2	CFM	1093 [516]	1050 [496]	1017 [480]	977 [461]	935 [441]	—	—
						RPM	671	725	764	809	852	—	—
						Watts	153	168	174	180	188	—	—
					3	CFM	—	—	—	—	1084 [512]	1040 [491]	1001 [472]
						RPM	—	—	—	—	896	936	971
						Watts	—	—	—	—	249	257	261
-3617 with 18 kW Heater	2.5 Ton	5	910/1059 CFM [429/500 L/s]	10x8 1/2 HP [373] 5 Speed	2	CFM	1068 [504]	1025 [484]	992 [468]	952 [449]	910 [429]	—	—
						RPM	711	765	804	849	892	—	—
						Watts	164	179	185	191	199	—	—
					3	CFM	—	—	—	—	1059 [500]	1015 [479]	976 [461]
						RPM	—	—	—	—	936	976	1011
						Watts	—	—	—	—	260	268	272
-3617 No Heater	3 Ton	5	1130/1275 CFM [533/602 L/s]	10x8 1/2 HP [373] 5 Speed	4	CFM	1270 [599]	1237 [584]	1199 [566]	1165 [550]	1130 [533]	—	—
						RPM	775	816	846	882	926	—	—
						Watts	237	249	259	268	277	—	—
					5	CFM	—	—	—	—	1275 [602]	1244 [587]	1211 [571]
						RPM	—	—	—	—	963	999	1029
						Watts	—	—	—	—	338	348	363
-3617 with 18 kW Heater	3 Ton	5	1105/1250 CFM [521/590 L/s]	10x8 1/2 HP [373] 5 Speed	4	CFM	1245 [588]	1212 [572]	1174 [554]	1140 [538]	1105 [521]	—	—
						RPM	815	856	886	922	966	—	—
						Watts	248	260	270	279	288	—	—
					5	CFM	—	—	—	—	1250 [590]	1219 [575]	1186 [560]
						RPM	—	—	—	—	1003	1039	1069
						Watts	—	—	—	—	349	359	374

Notes: X-13 motor speed changes.

All X-13 motors have 5 speed tabs. Speed tab 1 is for continuous fan. Speed tab 2 (low static) and Speed tab 3 (high static) are for lower tonnage. Speed tab 4 (low static) and Speed tab 5 (high static) are for higher tonnage.

X-13 air handlers are always shipped from factory at Speed tab 5, except for -4824, which is set at Speed tab 3. For instance, **17AHLA24HMA01 is always shipped at high static 2-ton airflow (Speed tab 5). To change to 1.5-ton airflow, move the blue wire to Speed tab 2 or 3 on the X-13 motor.

The low static Speed tab 2 (lower tonnage) and 4 (higher tonnage) are used for external static below 0.5" WC. The high static Speed tab 3 (lower tonnage) and 5 (higher tonnage) are used for external static exceeding 0.5" WC. Move the blue wire to the appropriate Speed tab as required by the application needs.

- The airflow for continuous fan (Speed tab 1) is always set at 50% of the Speed tab 4.
- The above airflow table lists the airflow information for air handlers without heater and air handler with maximum heater allowed for each model.
- The following formula can be used to calculate the approximate airflow, if a smaller (N kW) than the maximum heater kit is installed.

Approximate Airflow = Airflow without heater – (Airflow without heater – Airflow with maximum heater) x (N kW/maximum heater kW)

115/208/240V Airflow Performance Data—**AHLA/**AHL (X-13 Motor) (con't.)

Model No.	Tonnage Application	Motor Speed From Factory	Manufacturer Recommended Air-Flow Range (Min/Max) CFM	Blower Size/ Motor HP [W] # of Speed	Motor Speed	PSC CFM [L/s] Air Delivery/RPM/Watts—115/208/240 Volts							
						External Static Pressure—Inches W.C. [kPa]							
						0.1 [.02]	0.2 [.05]	0.3 [.07]	0.4 [.10]	0.5 [.12]	0.6 [.15]	0.7 [.17]	
-4821 No Heater	3.5 Ton	5	1337/1447 CFM [631/683 L/s]	10x10 3/4 HP [559] 5 Speed	2	CFM	1473 [695]	1442 [681]	1401 [661]	1373 [648]	1337 [631]	—	—
						RPM	781	825	867	905	949	—	—
						Watts	257	271	303	307	315	—	—
					3	CFM	—	—	—	—	1447 [683]	1433 [676]	1402 [662]
						RPM	—	—	—	—	987	1034	1065
						Watts	—	—	—	—	394	406	405
-4221 with 20 kW Heater	3.5 Ton	5	1297/1333 CFM [612/629 L/s]	10x10 3/4 HP [559] 5 Speed	2	CFM	1433 [676]	1402 [662]	1361 [642]	1333 [629]	1297 [612]	—	—
						RPM	831	875	919	954	989	—	—
						Watts	277	295	313	319	325	—	—
					3	CFM	—	—	—	—	1333 [629]	1300 [613]	1267 [598]
						RPM	—	—	—	—	1011	1046	1080
						Watts	—	—	—	—	350	364	377
-4821 No Heater	4 Ton	5	1535/1654 CFM [724/781 L/s]	10x10 3/4 HP [559] 5 Speed	4	CFM	1665 [786]	1631 [770]	1601 [756]	1572 [742]	1535 [724]	—	—
						RPM	853	893	934	968	1015	—	—
						Watts	351	387	401	406	422	—	—
					5	CFM	—	—	—	—	1654 [781]	1624 [766]	1563 [738]
						RPM	—	—	—	—	1036	1078	1095
						Watts	—	—	—	—	500	513	523
-4821 with 25 kW Heater	4 Ton	5	1495/1614 CFM [706/762 L/s]	10x10 3/4 HP [559] 2 Speed	4	CFM	1625 [767]	1591 [751]	1561 [737]	1532 [723]	1495 [706]	—	—
						RPM	894	932	970	1020	1052	—	—
						Watts	389	400	410	430	450	—	—
					5	CFM	—	—	—	—	1614 [762]	1584 [748]	1523 [719]
						RPM	—	—	—	—	1085	1090	1105
						Watts	—	—	—	—	514	520	530
-4824 No Heater	4 Ton	3	1545/1732 CFM [729/817 L/s]	11x11 3/4 HP [559] 5 Speed	2	CFM	1748 [825]	1669 [788]	1639 [773]	1599 [755]	1545 [729]	—	—
						RPM	660	698	734	762	795	—	—
						Watts	297	311	326	340	353	—	—
					3	CFM	—	—	—	—	1732 [817]	1683 [794]	1630 [769]
						RPM	—	—	—	—	840	872	899
						Watts	—	—	—	—	448	467	480
-4824 with 25 kW Heater	4 Ton	3	1505/1692 CFM [710/798 L/s]	11x11 3/4 HP [559] 5 Speed	2	CFM	1708 [806]	1629 [769]	1599 [755]	1559 [736]	1505 [710]	—	—
						RPM	680	736	760	790	820	—	—
						Watts	305	330	341	350	361	—	—
					3	CFM	—	—	—	—	1692 [798]	1643 [775]	1590 [750]
						RPM	—	—	—	—	865	890	1014
						Watts	—	—	—	—	460	470	481
-6024 No Heater	5 Ton	5	1739/1905 CFM [821/899 L/s]	11x11 3/4 HP [559] 5 Speed	4	CFM	1902 [898]	1862 [879]	1809 [854]	1781 [840]	1739 [821]	—	—
						RPM	712	749	787	815	856	—	—
						Watts	389	409	419	432	459	—	—
					5	CFM	—	—	—	—	1905 [899]	1866 [881]	1832 [865]
						RPM	—	—	—	—	894	924	950
						Watts	—	—	—	—	565	570	592
-6024 with 35 kW Heater	5 Ton	5	1699/1865 CFM [802/880 L/s]	11x11 3/4 HP [559] 5 Speed	4	CFM	1862 [879]	1822 [860]	1769 [835]	1741 [822]	1699 [802]	—	—
						RPM	750	790	810	850	880	—	—
						Watts	410	420	430	455	479	—	—
					5	CFM	—	—	—	—	1865 [880]	1826 [862]	1792 [846]
						RPM	—	—	—	—	920	945	970
						Watts	—	—	—	—	565	587	610

Notes: X-13 motor speed changes.

All X-13 motors have 5 speed tabs. Speed tab 1 is for continuous fan. Speed tab 2 (low static) and Speed tab 3 (high static) are for lower tonnage. Speed tab 4 (low static) and Speed tab 5 (high static) are for higher tonnage.

X-13 air handlers are always shipped from factory at Speed tab 5, except for -4824, which is set at Speed tab 3. For instance, **17AHLA24HMA01 is always shipped at high static 2-ton airflow (Speed tab 5). To change to 1.5-ton airflow, move the blue wire to Speed tab 2 or 3 on the X-13 motor.

The low static Speed tab 2 (lower tonnage) and 4 (higher tonnage) are used for external static below 0.5" WC. The high static Speed tab 3 (lower tonnage) and 5 (higher tonnage) are used for external static exceeding 0.5" WC. Move the blue wire to the appropriate Speed tab as required by the application needs.

- The airflow for continuous fan (Speed tab 1) is always set at 50% of the Speed tab 4.
- The above airflow table lists the airflow information for air handlers without heater and air handler with maximum heater allowed for each model.
- The following formula can be used to calculate the approximate airflow, if a smaller (N kW) than the maximum heater kit is installed.

Approximate Airflow = Airflow without heater – (Airflow without heater – Airflow with maximum heater) x (N kW/maximum heater kW)

**** AHSA/** AHSL Electrical Data – Blower Motor Only – No Electric Heat**

Cooling Capacity Tons	Voltage	Application Phase*	Hertz	HP [W]	RPM	Speeds	Circuit Amps.	Minimum Circuit Ampacity	Maximum Circuit Protector
1 1/2	115	1	60	1/5 [149]	1075	2	2.3	3.0	15
2				1/5 [149]	1075	2	3.8	5.0	15
2 1/2				1/4 [186]	1075	2	4.7	6.0	15
3				1/3 [249]	1075	2	6.1	8.0	15
3 1/2				1/2 [373]	1075	2	7.9	10.0	15
4				3/4 [559]	1075	2	8.4	11.0	15
1 1/2	208/240	1 & 3	60	1/5 [149]	1075	2	1.7	3.0	15
2				1/5 [149]	1075	2	1.7	3.0	15
2 1/2				1/4 [186]	1075	2	2.5	4.0	15
3				1/3 [249]	1075	2	2.5	4.0	15
3 1/2				1/2 [373]	1075	2	5.2	7.0	15
4				3/4 [559]	1075	2	5.2	7.0	15
3	480	3	60	1/3 [249]	1075	2	1.4	2.0	15
3 1/2				1/3 [249]	1075	2	2.1	3.0	15
4				3/4 [559]	1075	2	2.2	3.0	15

* Blower motors are all single phase motors.

**** AHLA/** AHLL Electrical Data – Blower Motor Only – No Electric Heat**

Cooling Capacity Tons	Voltage	Application Phase*	Hertz	HP [W]	RPM	Speeds	Circuit Amps.	Minimum Circuit Ampacity	Maximum Circuit Protector
1 1/2 & 2	208/240	1 & 3	60	1/3 [249]	300-1100	4	1.6	2.0	15
2 1/2 & 3				1/2 [373]	300-1100	4	2.7	4.0	15
3 1/2 & 4				3/4 [559]	300-1100	4	3.8	5.0	15
5				3/4 [559]	300-1100	4	4.6	6.0	15
1 1/2 & 2	115	1	60	1/3 [249]	300-1100	4	4.8	6.0	15
2 1/2 & 3				1/2 [373]	300-1100	4	6.8	9.0	15
3 1/2 & 4				3/4 [559]	300-1100	4	8.4	11.0	15
5				3/4 [559]	300-1100	4	8.4	11.0	15

* Blower motors are all single phase motors.

[] Designates Metric Conversions

AHSA/AHSL Electrical Data – with Electric Heat

Installation of the U.L. Listed original equipment manufacturer provided heater kits listed in the table below is recommended for all auxiliary heating requirements.

Nominal Cooling Capacity Tons/ Cabinet Size	Model No.	Heater kW 208/240V.	PH/Hz	No. Elements - kW Per	Circuit	Circuit Amps.	Motor Ampacity	Minimum Circuit Ampacity	Maximum Circuit Protection
1 1/2 & 2/17	RXBH-17A03J	2.25/3.0	1/60	1 - 3.0	SINGLE	10.8/12.5	1.7	16/18	20/20
	RXBH-17A05J	3.6/4.8	1/60	1 - 4.8	SINGLE	17.3/20.0	1.7	24/28	25/30
	RXBH-17A07J	5.4/7.2	1/60	2 - 3.6	SINGLE	26.0/30.0	1.7	35/40	35/40
	RXBH-17A10J	7.2/9.6	1/60	2 - 4.8	SINGLE	34.6/40.0	1.7	46/53	50/60
	RXBH-17A13J	9.4/12.5	1/60	3-4.17	SINGLE	45.1/52.1	1.7	59/68	60/70
	RXBH-17A13J	3.1/4.2	1/60	1-4.17	MULTIPLE CKT 1	15.0/17.4	1.7	21/24	25/25
		6.3/8.3	1/60	2-4.17	MULTIPLE CKT 2	30.1/34.7	0	38/44	40/45
	RXBH-17A07C	5.4/7.2	3/60	3 - 2.4	SINGLE	15.0/17.3	1.7	21/24	25/25
	RXBH-17A10C	7.2/9.6	3/60	3 - 3.2	SINGLE	20.0/23.1	1.7	28/31	30/35
RXBH-17A13C	9.4/12.5	3/60	3 - 4.17	SINGLE	26.1/30.1	1.7	35/40	35/40	
2 1/2 & 3/17	RXBH-17A03J	2.25/3.0	1/60	1 - 3.0	SINGLE	10.8/12.5	2.5	17/19	20/20
	RXBH-17A05J	3.6/4.8	1/60	1 - 4.8	SINGLE	17.3/20.0	2.5	25/29	25/30
	RXBH-17A07J	5.4/7.2	1/60	2 - 3.6	SINGLE	26.0/30.0	2.5	36/41	40/45
	RXBH-17A10J	7.2/9.6	1/60	2 - 4.8	SINGLE	34.6/40.0	2.5	47/54	50/60
	RXBH-17A13J	9.4/12.5	1/60	3-4.17	SINGLE	45.1/52.1	2.5	60/69	60/70
	RXBH-17A13J	3.1/4.2	1/60	1-4.17	MULTIPLE CKT 1	15.0/17.4	2.5	22/25	25/25
		6.3/8.3	1/60	2-4.17	MULTIPLE CKT 2	30.1/34.7	0	38/44	40/45
	RXBH-17A15J	10.8/14.4	1/60	3-4.8	SINGLE	51.9/60.0	2.5	68/79	70/80
	RXBH-17A15J	3.6/4.8	1/60	1 - 4.8	MULTIPLE CKT 1	17.3/20.0	2.5	25/29	25/30
		7.2/9.6	1/60	2 - 4.8	MULTIPLE CKT 2	34.6/40.0	0	44/50	45/50
	RXBH-17A18J	12.8/17.0	1/60	3-5.68	SINGLE	61.6/70.8	2.5	81/92	90/100
	RXBH-17A18J	4.3/5.7	1/60	1-5.68	MULTIPLE CKT 1	20.5/23.6	2.5	29/33	30/35
		8.5/11.3	1/60	2 - 5.68	MULTIPLE CKT 2	41.1/47.2	0	52/59	60/60
	RXBH-17A07C	5.4/7.2	3/60	3 - 2.4	SINGLE	15.0/17.3	2.5	22/25	25/25
	RXBH-17A10C	7.2/9.6	3/60	3 - 3.2	SINGLE	20.0/23.1	2.5	29/32	30/35
	RXBH-17A13C	9.4/12.5	3/60	3 - 4.17	SINGLE	26.1/30.1	2.5	36/41	40/45
	RXBH-17A15C	10.8/14.4	3/60	3 - 4.8	SINGLE	30.0/34.6	2.5	41/47	45/50
	RXBH-17A18C	12.8/17.0	3/60	3-5.68	SINGLE	35.5/41.0	2.5	48/55	50/60
	RXBH-17A07D	7.2	3/60	2-3.6	SINGLE	8.7	1.4	13	15
	RXBH-17A10D	9.6	3/60	3 - 3.2	SINGLE	11.6	1.4	17	20
RXBH-17A15D	14.4	3/60	3 - 4.8	SINGLE	17.3	1.4	24	25	
RXBH-17A18D	17	3/60	3 - 5.68	SINGLE	20.4	1.4	28	30	
3/21	RXBH-24A05J	3.6/4.8	1/60	1 - 4.8	SINGLE	17.3/20.0	2.5	25/29	25/30
	RXBH-24A07J	5.4/7.2	1/60	2 - 3.6	SINGLE	26.0/30.0	2.5	36/41	40/45
	RXBH-24A10J	7.2/9.6	1/60	2 - 4.8	SINGLE	34.6/40.0	2.5	47/54	50/60
	RXBH-24A15J	10.8/14.4	1/60	3-4.8	SINGLE	51.9/60.0	2.5	68/79	70/80
	RXBH-24A15J	3.6/4.8	1/60	1 - 4.8	MULTIPLE CKT 1	17.3/20.0	2.5	25/29	25/30
		7.2/9.6	1/60	2 - 4.8	MULTIPLE CKT 2	34.6/40.0	0	44/50	45/50
	RXBH-24A18J	12.8/17.0	1/60	4-4.26	SINGLE	61.6/70.8	2.5	81/92	90/100
	RXBH-24A18J	6.4/8.5	1/60	2 - 4.26	MULTIPLE CKT 1	30.8/35.4	2.5	42/48	45/50
		6.4/8.5	1/60	2 - 4.26	MULTIPLE CKT 2	30.8/35.4	0	39/45	40/45
	RXBH-24A07C	5.4/7.2	3/60	3 - 2.4	SINGLE	15.0/17.3	2.5	22/25	25/25
	RXBH-24A10C	7.2/9.6	3/60	3 - 3.2	SINGLE	20.0/23.1	2.5	29/32	30/35
	RXBH-24A15C	10.8/14.4	3/60	3 - 4.8	SINGLE	30.0/34.6	2.5	41/47	45/50
	RXBH-24A18C	12.8/17.0	3/60	3-5.68	SINGLE	35.5/41.0	2.5	48/55	50/60
	RXBH-24A07D	7.2	3/60	2-3.6	SINGLE	8.7	1.4	13	15
	RXBH-24A10D	9.6	3/60	3 - 3.2	SINGLE	11.6	1.4	17	20
RXBH-24A15D	14.4	3/60	3 - 4.8	SINGLE	17.3	1.4	24	25	
RXBH-24A18D	17	3/60	3 - 5.68	SINGLE	20.4	1.4	28	30	

- Supply circuit protective devices may be fused or "HACR" type circuit breakers.
- If non-standard fuse size is specified, use next size larger standard fuse size.
- If the kit is listed under both single and multiple circuits, the kit is shipped from factory as multiple circuits. For single phase application, Jumper bar kit RXBJ-A21 and RXBJ-A31 can be used to convert multiple circuits to a single supply circuit. Refer to Accessory Section for details.
- Largest motor load is included in single circuit or circuit 1 of multiple circuit.
- Heater loads are balanced on 3 PH. models with 3 or 6 heaters only.
- Electric heater BTUH - (heater watts + motor watts) x 3.414 (see airflow table for motor watts.)

- No electrical heating elements are permitted to be used with A voltage (115V) air handler.
- J voltage (230V) single phase air handler is designed to be used with single or three phase 230 volt electric heaters. In the case of connecting 3 phase power to air handler terminal block without the heater, bring only two leads to terminal block. Cap, insulate and fully secure the third lead.
- Do not use 480 volts electrical heaters on 230 volts air handlers.
- Do not use 230 volts electrical heaters on 480 volts air handlers.

AHSA/AHSL Electrical Data – with Electric Heat (con't.)

Installation of the U.L. Listed original equipment manufacturer provided heater kits listed in the table below is recommended for all auxiliary heating requirements.

Nominal Cooling Capacity Tons/ Cabinet Size	Model No.	Heater kW 208/240V.	PH/Hz	No. Elements - kW Per	Circuit	Circuit Amps.	Motor Ampacity	Minimum Circuit Ampacity	Maximum Circuit Protection
3 1/2 & 4/ 21 and 4/ 24	RXBH-24A05J	3.6/4.8	1/60	1 - 4.8	SINGLE	17.3/20.0	4.0	27/30	30/30
	RXBH-24A07J	5.4/7.2	1/60	2 - 3.6	SINGLE	26.0/30.0	4.0	38/43	40/45
	RXBH-24A10J	7.2/9.6	1/60	2 - 4.8	SINGLE	34.6/40.0	4.0	49/55	50/60
	RXBH-24A15J	10.8/14.4	1/60	3-4.8	SINGLE	51.9/60.0	4.0	70/80	70/80
	RXBH-24A15J	3.6/4.8	1/60	1 - 4.8	MULTIPLE CKT 1	17.3/20.0	4.0	27/30	30/30
		7.2/9.6	1/60	2 - 4.8	MULTIPLE CKT 2	34.6/40.0	0.0	44/50	45/50
	RXBH-24A18J	12.8/17	1/60	4-4.26	SINGLE	61.6/70.8	4.0	82/94	90/100
	RXBH-24A18J	6.4/8.5	1/60	2 - 4.26	MULTIPLE CKT 1	30.8/35.4	4.0	44/50	45/50
		6.4/8.5	1/60	2 - 4.26	MULTIPLE CKT 2	30.8/35.4	0.0	39/45	40/45
	RXBH-24A20J	14.4/19.2	1/60	4-4.8	SINGLE	69.2/80	4.0	92/105	100/110
	RXBH-24A20J	7.2/9.6	1/60	2 - 4.8	MULTIPLE CKT 1	34.6/40.0	4.0	49/55	50/60
		7.2/9.6	1/60	2 - 4.8	MULTIPLE CKT 2	34.6/40.0	0.0	44/50	45/50
	RXBH-24A25J	18.0/24.0	1/60	6-4.0	SINGLE	86.4/99.9	4.0	113/130	125/150
	RXBH-24A25J (4-ton only)	6.0/8.0	1/60	2 - 4.0	MULTIPLE CKT 1	28.8/33.3	4.0	42/47	45/50
		6.0/8.0	1/60	2 - 4.0	MULTIPLE CKT 2	28.8/33.3	0.0	36/42	40/45
		6.0/8.0	1/60	2 - 4.0	MULTIPLE CKT 3	28.8/33.3	0.0	36/42	40/45
	RXBH-24A07C	5.4/7.2	3/60	3 - 2.4	SINGLE	15.0/17.3	4.0	24/27	25/30
	RXBH-24A10C	7.2/9.6	3/60	3 - 3.2	SINGLE	20.0/23.1	4.0	30/34	30/35
	RXBH-24A15C	10.8/14.4	3/60	3 - 4.8	SINGLE	30.0/34.6	4.0	43/49	45/50
	RXBH-24A18C	12.8/17.0	3/60	3-2.84	SINGLE	35.6/41.0	4.0	50/57	50/60
	RXBH-24A20C*	14.4/19.2	3/60	3-3.2	SINGLE	40.0/46.2	4.0	55/63	60/70
	RXBH-24A20C	7.2/9.6	3/60	3 - 3.2	MULTIPLE CKT 1	20.0/23.1	4.0	30/34	30/35
		7.2/9.6	3/60	3 - 3.2	MULTIPLE CKT 2	20.0/23.1	0.0	25/29	25/30
	RXBH-24A25C*	18.0/24.0	3/60	6-4.0	SINGLE	50.0/57.8	4.0	68/78	70/80
	RXBH-24A25C (4-ton only)	9.0/12.0	3/60	3 - 4.0	MULTIPLE CKT 1	25.0/28.9	4.0	37/42	40/45
		9.0/12.0	3/60	3 - 4.0	MULTIPLE CKT 2	25.0/28.9	0.0	32/37	35/40
	RXBH-24A07D	7.2	3/60	2-3.6	SINGLE	8.7	2.2	14	15
	RXBH-24A10D	9.6	3/60	3 - 3.2	SINGLE	11.6	2.2	18	20
	RXBH-24A15D	14.4	3/60	3 - 4.8	SINGLE	17.3	2.2	25	25
	RXBH-24A18D	17	3/60	3 - 5.68	SINGLE	20.4	2.2	29	30
	RXBH-24A20D	19.2	3/60	6 - 3.2	SINGLE	23.2	2.2	32	35
RXBH-24A25D (4-ton only)	24.0	3/60	6 - 4.0	SINGLE	28.8	2.2	39	40	

* Values only. No single point kit available.

- Supply circuit protective devices may be fused or "HACR" type circuit breakers.
- If non-standard fuse size is specified, use next size larger standard fuse size.
- If the kit is listed under both single and multiple circuits, the kit is shipped from factory as multiple circuits. For single phase application, Jumper bar kit RXBJ-A21 and RXBJ-A31 can be used to convert multiple circuits to a single supply circuit. Refer to Accessory Section for details.
- Largest motor load is included in single circuit or circuit 1 of multiple circuit.
- Heater loads are balanced on 3 PH. models with 3 or 6 heaters only.

- Electric heater BTUH - (heater watts + motor watts) x 3.414 (see airflow table for motor watts.)
- No electrical heating elements are permitted to be used with A voltage (115V) air handler.
- J voltage (230V) single phase air handler is designed to be used with single or three phase 230 volt electric heaters. In the case of connecting 3 phase power to air handler terminal block without the heater, bring only two leads to terminal block. Cap, insulate and fully secure the third lead.
- Do not use 480 volts electrical heaters on 230 volts air handlers.
- Do not use 230 volts electrical heaters on 480 volts air handlers.

AHLA/AHL Electrical Data – with Electric Heat

Installation of the U.L. Listed original equipment manufacturer provided heater kits listed in the table below is recommended for all auxiliary heating requirements.

Nominal Cooling Capacity Tons/ Cabinet Size	Model No.	Heater KW 208/240V	PH/HZ	No. Elements - KW Per	Type Supply Circuit Single Circuit Multiple Circuit	Circuit Amps.	Motor Ampacity	Minimum Circuit Ampacity	Maximum Circuit Protection
1 1/2 & 2/ 17	RXBH-17A03J	2.25/3.0	1/60	1 - 3.0	SINGLE	10.8/12.5	1.6	16/18	20/20
	RXBH-17A05J	3.6/4.8	1/60	1 - 4.8	SINGLE	17.3/20.0	1.6	24/27	25/30
	RXBH-17A07J	5.4/7.2	1/60	2 - 3.6	SINGLE	26.0/30.0	1.6	35/40	35/40
	RXBH-17A10J	7.2/9.6	1/60	2 - 4.8	SINGLE	34.6/40.0	1.6	46/52	50/60
	RXBH-17A13J	9.4/12.5	1/60	3-4.17	SINGLE	45.1/52.1	1.6	59/68	60/70
	RXBH-17A13J	3.1/4.2	1/60	1-4.17	MULTIPLE CKT 1	15.0/17.4	1.6	21/24	25/25
		6.3/8.3	1/60	2-4.17	MULTIPLE CKT 2	30.1/34.7	0	38/44	40/45
	RXBH-17A07C	5.4/7.2	3/60	3 - 2.4	SINGLE	15.0/17.3	1.6	21/24	25/25
RXBH-17A10C	7.2/9.6	3/60	3 - 3.2	SINGLE	20.0/23.1	1.6	27/31	30/35	
RXBH-17A13C	9.4/12.5	3/60	3 - 4.17	SINGLE	26.1/30.1	1.6	35/40	35/40	
2 1/2 & 3/ 17	RXBH-17A03J	2.25/3.0	1/60	1 - 3.0	SINGLE	10.8/12.5	2.7	17/19	20/20
	RXBH-17A05J	3.6/4.8	1/60	1 - 4.8	SINGLE	17.3/20.0	2.7	25/29	25/30
	RXBH-17A07J	5.4/7.2	1/60	2 - 3.6	SINGLE	26.0/30.0	2.7	36/41	40/45
	RXBH-17A10J	7.2/9.6	1/60	2 - 4.8	SINGLE	34.6/40.0	2.7	47/54	50/60
	RXBH-17A13J	9.4/12.5	1/60	3-4.17	SINGLE	45.1/52.1	2.7	60/69	60/70
	RXBH-17A13J	3.1/4.2	1/60	1-4.17	MULTIPLE CKT 1	15.0/17.4	2.7	23/26	25/30
		6.3/8.3	1/60	2-4.17	MULTIPLE CKT 2	30.1/34.7	0	38/44	40/45
	RXBH-17A15J	10.8/14.4	1/60	3-4.8	SINGLE	51.9/60.0	2.7	69/79	70/80
	RXBH-17A15J	3.6/4.8	1/60	1 - 4.8	MULTIPLE CKT 1	17.3/20.0	2.7	25/29	25/30
		7.2/9.6	1/60	2 - 4.8	MULTIPLE CKT 2	34.6/40.0	0	44/50	45/50
	RXBH-17A18J	12.8/17.0	1/60	3-5.68	SINGLE	61.6/70.8	2.7	81/92	90/100
	RXBH-17A18J	4.3/5.7	1/60	1-5.68	MULTIPLE CKT 1	20.5/23.6	2.7	29/33	30/35
		8.5/11.3	1/60	2 - 5.68	MULTIPLE CKT 2	41.1/47.2	0	52/59	60/60
	RXBH-17A07C	5.4/7.2	3/60	3 - 2.4	SINGLE	15.0/17.3	2.7	23/25	25/25
	RXBH-17A10C	7.2/9.6	3/60	3 - 3.2	SINGLE	20.0/23.1	2.7	29/33	30/35
	RXBH-17A13C	9.4/12.5	3/60	3 - 4.17	SINGLE	26.1/30.1	2.7	36/41	40/45
RXBH-17A15C	10.8/14.4	3/60	3 - 4.8	SINGLE	30.0/34.6	2.7	41/47	45/50	
RXBH-17A18C	12.8/17.0	3/60	3-5.68	SINGLE	35.5/41.0	2.7	48/55	50/60	
3 1/2 & 4/ 21	RXBH-24A05J	3.6/4.8	1/60	1 - 4.8	SINGLE	17.3/20.0	3.8	27/30	30/30
	RXBH-24A07J	5.4/7.2	1/60	2 - 3.6	SINGLE	26.0/30.0	3.8	38/43	40/45
	RXBH-24A10J	7.2/9.6	1/60	2 - 4.8	SINGLE	34.6/40.0	3.8	48/55	50/60
	RXBH-24A15J	10.8/14.4	1/60	3-4.8	SINGLE	51.9/60.0	3.8	70/80	70/80
	RXBH-24A15J	3.6/4.8	1/60	1 - 4.8	MULTIPLE CKT 1	17.3/20.0	3.8	27/30	30/30
		7.2/9.6	1/60	2 - 4.8	MULTIPLE CKT 2	34.6/40.0	0.0	44/50	45/50
	RXBH-24A18J	12.8/17	1/60	4-4.26	SINGLE	61.6/70.8	3.8	82/94	90/100
	RXBH-24A18J	6.4/8.5	1/60	2 - 4.26	MULTIPLE CKT 1	30.8/35.4	3.8	44/49	45/50
		6.4/8.5	1/60	2 - 4.26	MULTIPLE CKT 2	30.8/35.4	0.0	39/45	40/45
	RXBH-24A20J	14.4/19.2	1/60	4-4.8	SINGLE	69.2/80	3.8	92/105	100/110
	RXBH-24A20J	7.2/9.6	1/60	2 - 4.8	MULTIPLE CKT 1	34.6/40.0	3.8	48/55	50/60
		7.2/9.6	1/60	2 - 4.8	MULTIPLE CKT 2	34.6/40.0	0.0	44/50	45/50
	RXBH-24A25J	18.0/24.0	1/60	6-4.0	SINGLE	86.4/99.9	3.8	113/130	125/150
	RXBH-24A25J (4-ton only)	6.0/8.0	1/60	2 - 4.0	MULTIPLE CKT 1	28.8/33.3	3.8	41/47	45/50
		6.0/8.0	1/60	2 - 4.0	MULTIPLE CKT 2	28.8/33.3	0.0	36/42	40/45
		6.0/8.0	1/60	2 - 4.0	MULTIPLE CKT 3	28.8/33.3	0.0	36/42	40/45
	RXBH-24A07C	5.4/7.2	3/60	3 - 2.4	SINGLE	15.0/17.3	3.8	24/27	25/30
	RXBH-24A10C	7.2/9.6	3/60	3 - 3.2	SINGLE	20.0/23.1	3.8	30/34	30/35
	RXBH-24A15C	10.8/14.4	3/60	3 - 4.8	SINGLE	30.0/34.6	3.8	43/48	45/50
	RXBH-24A18C	12.8/17.0	3/60	3-2.84	SINGLE	35.6/41.0	3.8	50/56	50/60
	RXBH-24A20C*	14.4/19.2	3/60	3-3.2	SINGLE	40.0/46.2	3.8	55/63	60/70
	RXBH-24A20C	7.2/9.6	3/60	3 - 3.2	MULTIPLE CKT 1	20.0/23.1	3.8	30/34	30/35
		7.2/9.6	3/60	3 - 3.2	MULTIPLE CKT 2	20.0/23.1	0.0	25/29	25/30
	RXBH-24A25C*	18.0/24.0	3/60	6-4.0	SINGLE	50.0/57.8	3.8	68/77	70/80
RXBH-24A25C (4-ton only)	9.0/12.0	3/60	3 - 4.0	MULTIPLE CKT 1	25.0/28.9	3.8	36/41	40/45	
	9.0/12.0	3/60	3 - 4.0	MULTIPLE CKT 2	25.0/28.9	0.0	32/37	35/40	

* Values only. No single point kit available.

- Supply circuit protective devices may be fused or "HACR" type circuit breakers.
- If non-standard fuse size is specified, use next size larger standard fuse size.
- If the kit is listed under both single and multiple circuits, the kit is shipped from factory as multiple circuits. For single phase application, Jumper bar kit RXBJ-A21 and RXBJ-A31 can be used to convert multiple circuits to a single supply circuit. Refer to Accessory Section for details.
- Largest motor load is included in single circuit or circuit 1 of multiple circuit.
- Heater loads are balanced on 3 PH. models with 3 or 6 heaters only.

- Electric heater BTUH - (heater watts + motor watts) x 3.414 (see airflow table for motor watts.)
- No electrical heating elements are permitted to be used with A voltage (115V) air handler.
- J voltage (230V) single phase air handler is designed to be used with single or three phase 230 volt electric heaters. In the case of connecting 3 phase power to air handler terminal block without the heater, bring only two leads to terminal block. Cap, insulate and fully secure the third lead.
- Do not use 480 volts electrical heaters on 230 volts air handlers.
- Do not use 230 volts electrical heaters on 480 volts air handlers.

AHLA/AHL Electrical Data – with Electric Heat (con't.)

Installation of the U.L. Listed original equipment manufacturer provided heater kits listed in the table below is recommended for all auxiliary heating requirements.

Nominal Cooling Capacity Tons/ Cabinet Size	Model No.	Heater KW 208/240V	PH/HZ	No. Elements - KW Per	Type Supply Circuit Single Circuit Multiple Circuit	Circuit Amps.	Motor Ampacity	Minimum Circuit Ampacity	Maximum Circuit Protection
4 & 5/ 24	RXBH-24A07J	5.4/7.2	1/60	2 - 3.6	SINGLE	26.0/30.0	4.6	39/44	40/45
	RXBH-24A10J	7.2/9.6	1/60	2 - 4.8	SINGLE	34.6/40.0	4.6	49/56	50/60
	RXBH-24A15J	10.8/14.4	1/60	3-4.8	SINGLE	51.9/60.0	4.6	71/81	80/90
	RXBH-24A15J	3.6/4.8	1/60	1 - 4.8	MULTIPLE CKT 1	17.3/20.0	4.6	28/31	30/35
		7.2/9.6	1/60	2 - 4.8	MULTIPLE CKT 2	34.6/40.0	0	44/50	45/50
	RXBH-24A18J	12.8/17	1/60	4-4.26	SINGLE	61.6/70.8	4.6	83/95	90/100
	RXBH-24A18J	6.4/8.5	1/60	2 - 4.26	MULTIPLE CKT 1	30.8/35.4	4.6	45/50	45/50
		6.4/8.5	1/60	2 - 4.26	MULTIPLE CKT 2	30.8/35.4	0	39/45	40/45
	RXBH-24A20J	14.4/19.2	1/60	4-4.8	SINGLE	69.2/80	4.6	93/106	100/110
	RXBH-24A20J	7.2/9.6	1/60	2 - 4.8	MULTIPLE CKT 1	34.6/40.0	4.6	49/56	50/60
		7.2/9.6	1/60	2 - 4.8	MULTIPLE CKT 2	34.6/40.0	0	44/50	45/50
	RXBH-24A25J	18.0/24.0	1/60	6-4.0	SINGLE	86.4/99.9	4.6	114/131	125/150
	RXBH-24A25J	6.0/8.0	1/60	2 - 4.0	MULTIPLE CKT 1	28.8/33.3	4.6	42/48	45/50
		6.0/8.0	1/60	2 - 4.0	MULTIPLE CKT 2	28.8/33.3	0	36/42	40/45
		6.0/8.0	1/60	2 - 4.0	MULTIPLE CKT 3	28.8/33.3	0	36/42	40/45
	RXBH-24A30J	21.6/28.8	1/60	6-4.8	SINGLE	103.8/120.	4.6	136/156	150/175
	RXBH-24A30J (5-ton only)	7.2/9.6	1/60	2 - 4.8	MULTIPLE CKT 1	34.6/40.0	4.6	49/56	50/60
		7.2/9.6	1/60	2 - 4.8	MULTIPLE CKT 2	34.6/40.0	0	44/50	45/50
		7.2/9.6	1/60	2 - 4.8	MULTIPLE CKT 3	34.6/40.0	0	44/50	45/50
	RXBH-24A07C	5.4/7.2	3/60	3 - 2.4	SINGLE	15.0/17.3	4.6	25/28	25/30
	RXBH-24A10C	7.2/9.6	3/60	3 - 3.2	SINGLE	20.0/23.1	4.6	31/35	35/35
	RXBH-24A15C	10.8/14.4	3/60	3 - 4.8	SINGLE	30.0/34.6	4.6	44/49	45/50
	RXBH-24A18C	12.8/17.0	3/60	3-2.84	SINGLE	35.6/41.0	4.6	51/57	60/60
	RXBH-24A20C*	14.4/19.2	3/60	3-3.2	SINGLE	40.0/46.2	4.6	56/64	60/70
	RXBH-24A20C	7.2/9.6	3/60	3 - 3.2	MULTIPLE CKT 1	20.0/23.1	4.6	31/35	35/35
		7.2/9.6	3/60	3 - 3.2	MULTIPLE CKT 2	20.0/23.1	0	25/29	25/30
	RXBH-24A25C*	18.0/24.0	3/60	6-4.0	SINGLE	50.0/57.8	4.6	69/78	70/80
	RXBH-24A25C	9.0/12.0	3/60	3 - 4.0	MULTIPLE CKT 1	25.0/28.9	4.6	37/42	40/45
		9.0/12.0	3/60	3 - 4.0	MULTIPLE CKT 2	25.0/28.9	0	32/37	35/40
	RXBH-24A30C*	21.6/28.8	3/60	6-4.8	SINGLE	60.0/69.4	4.6	81/93	90/100
	RXBH-24A30C (5-ton only)	10.8/14.4	3/60	3 - 4.8	MULTIPLE CKT 1	30.0/34.7	4.6	44/50	45/50
		10.8/14.4	3/60	3 - 4.8	MULTIPLE CKT 2	30.0/34.7	0	38/44	40/45

* Values only. No single point kit available.

- Supply circuit protective devices may be fused or "HACR" type circuit breakers.
- If non-standard fuse size is specified, use next size larger standard fuse size.
- If the kit is listed under both single and multiple circuits, the kit is shipped from factory as multiple circuits. For single phase application, Jumper bar kit RXBJ-A21 and RXBJ-A31 can be used to convert multiple circuits to a single supply circuit. Refer to Accessory Section for details.
- Largest motor load is included in single circuit or circuit 1 of multiple circuit.
- Heater loads are balanced on 3 PH. models with 3 or 6 heaters only.

- Electric heater BTUH - (heater watts + motor watts) x 3.414 (see airflow table for motor watts.)
- No electrical heating elements are permitted to be used with A voltage (115V) air handler.
- J voltage (230V) single phase air handler is designed to be used with single or three phase 230 volt electric heaters. In the case of connecting 3 phase power to air handler terminal block without the heater, bring only two leads to terminal block. Cap, insulate and fully secure the third lead.
- Do not use 480 volts electrical heaters on 230 volts air handlers.
- Do not use 230 volts electrical heaters on 480 volts air handlers.

Electrical Wiring:

Power Wiring

- Field wiring must comply with the National Electrical Code (C.E.C. in Canada) and any applicable local ordinance.
- Supply wiring must be 75°C minimum copper conductors only.
- See electrical data for product Ampacity rating and Circuit Protector requirement.

Grounding

- This product must be sufficiently grounded in accordance with National Electrical Code (C.E.C. in Canada) and any applicable local ordinance.
- A grounding lug is provided.

Accessories-Kits—Parts

• Combustible Floor Base RXHB-

Model Cabinet Size	Combustible Floor Base Model Number
17	RXHB-17
21	RXHB-21
24	RXHB-24

- **Jumper Bar Kit 3 Ckt. to 1 Ckt. RXBJ-A31** is used to convert single phase multiple three circuit units to a single supply circuit. Kit includes cover and screw for line side terminals.
- **Jumper Bar Kit 2 Ckt. to 1 Ckt. RXBJ-A21** is used to convert single phase multiple two circuit units to a single supply circuit. Kit includes cover and screw for line side terminals.
- **Note:** No jumper bar kit is available to convert three phase multiple two circuit units to a single supply circuit.

• Auxiliary Horizontal Overflow Pan Accessory RXBM-

Nominal Cooling Capacity-Tons	Auxiliary Horizontal Overflow Pan Accessory Model Number
1½ - 3	RXBM-AC48
3½ - 5	RXBM-AC61

• External Filter Rack RXHF-B17, B21, B24

Model Cabinet Size	Filter Size In. [mm]	Part Number*	A	B
17	16 x 20 [406 x 508]	RXHF-B17	16.90	20.77
21	20 x 20 [508 x 508]	RXHF-B21	20.40	20.77
24	25 x 20 [635 x 508]	RXHF-B24	25.00	21.04

*Accommodates 1" filter

• Auxiliary Electric Heater Kits RXBH-

Heater Kits include circuit breakers which meet UL and cUL requirements for service disconnect. See the Electric Heat Electrical Data in this specification sheet for specific Heater Kit Model numbers.

• Horizontal Adapter Kit RXHH-

This horizontal adapter kit is used to convert Upflow/Downflow only models to horizontal flow. See the following table to order proper horizontal adapter kit.

Coil Model	Horizontal Adapter Kit Model Number (Single Qty.)	Horizontal Adapter Kit Model Number (10-Pack Qty.)
2414	RXHH-A01	RXHH-A01 x 10
2417	RXHH-A02	RXHH-A02 x 10
3617/3621	RXHH-A03	RXHH-A03 x 10
4821/4824	RXHH-A04	RXHH-A04 x 10
6024	RXHH-A05	RXHH-A05 x 10

• External Filter Base RXHF-

Model Cabinet Size	Filter Size In. [mm]	Part Number*	A	B
17	16 x 20 [406 x 508]	RXHF-17	15.70	17.5
21	20 x 20 [508 x 508]	RXHF-21	19.20	21.0
24	25 x 20 [635 x 508]	RXHF-24	22.70	25.5

*Accommodates 1" or 2" filter

[] Designates Metric Conversions

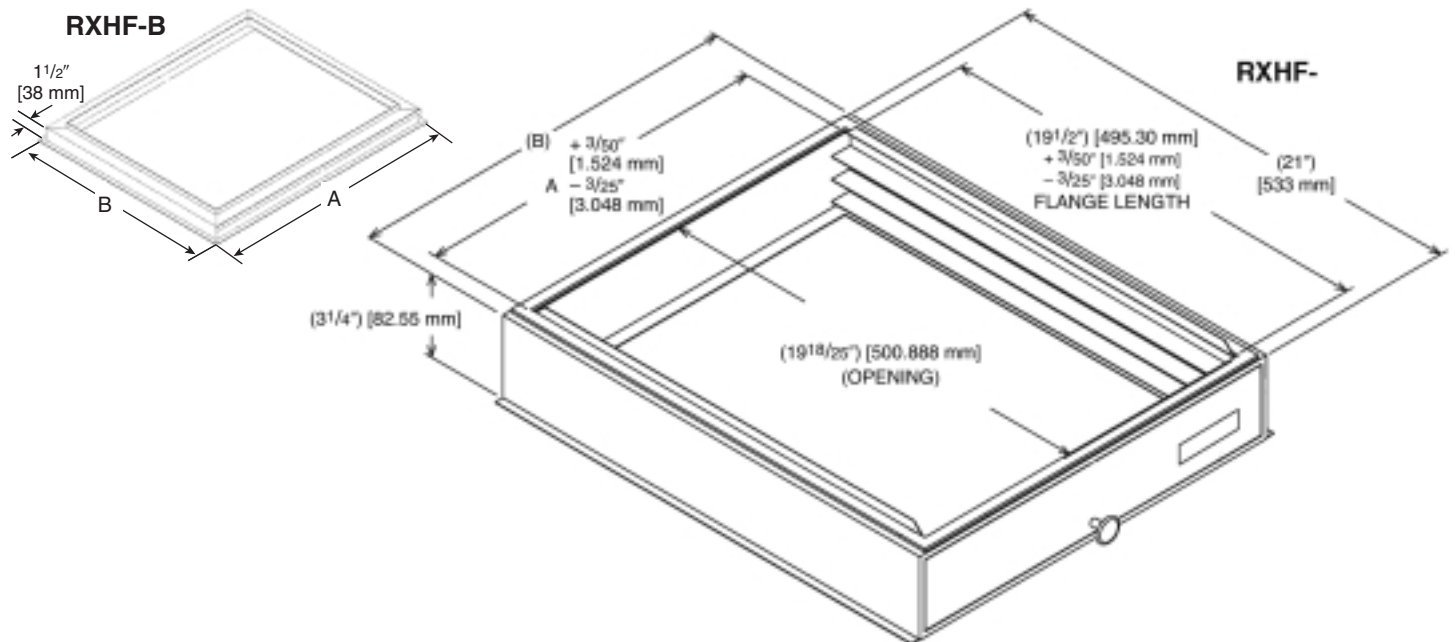

NOTES

Before proceeding with installation, refer to installation instructions packaged with each model, as well as complying with all Federal, State, Provincial, and Local codes, regulations, and practices.



"In keeping with its policy of continuous progress and product improvement, ICECO reserves the right to make changes without notice."