



13 SEER HEAT PUMPS

Features

- Coils constructed with copper tubing and enhanced aluminum fins.
- Strong, attractive cabinet—louvered design protects the coil from damage.
- Expansion Valves with Internal Check Valve—Provides for quieter refrigerant metering.
- Demand Defrost Control
- Non-Cycling Reversing Valve
- Hot Gas Muffler
- Service Valves
- Grille/motor mount for quiet fan operation.
- Easily accessible control box.
- Certified and rated under A.R.I. Standard 240.
- U.L listed.

Accessories/Options

- Low Ambient Control (Model No. RXPZ-C01)
- Outdoor Thermostats (Model No. RXPT-A01, A02, A03 or A04)
- Heat Pump Monitor (Model No. RXPM-B01)
- Thermostats and Subbases
(Available through the PROSTOCK® department)
- Compressor Time Delay Control (Model No. RXMD-B01)
- Blower Time Delay Control (Model No. RXMD-C04)
RXMD-C04 is not required if the outdoor unit is matched with a WeatherKing® furnace or air handler, or if the furnace or air handler used has a blower off time delay built-in.
- Sound Enclosure*
- High Pressure Control (Model No. RXAB-A03)
- Bi-Directional Filter Drier*
- Start Components*

*Available through the PROSTOCK® department.

Applications

WeatherKing® remote heat pumps offer comfort and dependability for single, multi-family and light commercial applications.

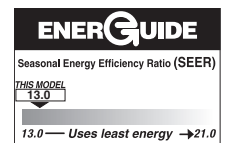

Model Identification Number

13	P	J	A	18	A	01
13 SEER	P = HEAT PUMP	VOLTAGE J = 208-230 SINGLE PHASE	DESIGN SERIES A = 1ST DESIGN	NOMINAL COOLING CAPACITY 18 = 18,000 BTU/HR [5.28 kW] 24 = 24,000 BTU/HR [7.03 kW] 30 = 30,000 BTU/HR [8.79 kW] 36 = 36,000 BTU/HR [10.55 kW] 42 = 42,000 BTU/HR [12.31 kW] 48 = 48,000 BTU/HR [14.07 kW] 60 = 60,000 BTU/HR [17.58 kW]	CABINET A = FULL METAL JACKET	WEATHERKING

Performance Data ARI Standard Conditions

Note: Only these combinations of indoor/outdoor units are approved and any other combinations should not be used.

Model Numbers		ARI Cooling Performance							ARI Htg. Performance (70°F [21.0°C] Indoor)				
		80°F [26.5°C] DB/67°F [19.5°C] WB Indoor Air 95°F [35.0°C] DB Outdoor Air							Outdoor Air 47°F DB/43°F WB [8.5°C/6.0°C] DOE High Temp.		Outdoor Air 17°F DB/15°F WB [-8.5°C/-9.5°C] DOE Low Temp.		DOE Region IV HSPF
Outdoor Unit 13PJA	Indoor Coil and/or Air Handler	Total Capacity BTU/H [kW]	Net Sens. BTU/H [kW]	Net Latent BTU/H [kW]	EER	SEER	Snd. Rate dB	Indoor CFM [L/s]	BTU/H [kW]	COP	BTU/H [kW]	COP	
18	17AHS18HM (RCSA-H*2417A*) ①	18,000 [5.3]	13,100 [3.8]	4,900 [1.4]	11.90	13.00	76	600 [283]	15,900 [4.7]	3.46	8,500 [2.5]	2.26	7.7
	RCFA-H*2414A*	17,600 [5.2]	12,550 [3.7]	5,050 [1.5]	11.70	13.00	76	550 [260]	15,900 [4.7]	3.38	8,800 [2.6]	2.12	7.7
	RCFA-H*2417A*	17,600 [5.2]	12,550 [3.7]	5,050 [1.5]	11.70	13.00	76	550 [260]	15,900 [4.7]	3.38	8,800 [2.6]	2.12	7.7
	17AHBA24HM (RCHJ-24A1)	16,700 [4.9]	12,050 [3.5]	4,650 [1.4]	12.00	13.00	76	600 [283]	15,500 [4.5]	3.74	8,800 [2.6]	2.60	7.7
	(-)BHK-17 (RCHJ-24A1)	16,800 [4.9]	12,100 [3.5]	4,700 [1.4]	12.25	13.00	76	600 [283]	15,600 [4.6]	3.64	8,900 [2.6]	2.52	7.7
	(-)BHP-17 (RCHJ-24A1)	16,700 [4.9]	12,050 [3.5]	4,650 [1.4]	12.00	13.00	76	600 [283]	15,500 [4.5]	3.74	8,800 [2.6]	2.60	7.7
	17AHLA24HM (RCSA-H*2417A*)	18,300 [5.4]	13,300 [3.9]	5,000 [1.5]	12.95	14.00	76	600 [283]	15,300 [4.5]	3.66	8,100 [2.4]	2.26	8.2
	(-)HLA-HM2417 (RCSA-H*2417A*)	18,300 [5.4]	13,300 [3.9]	5,000 [1.5]	12.95	14.00	76	600 [283]	15,300 [4.5]	3.66	8,100 [2.4]	2.26	8.2
	(-)HSA-HM1817 (RCSA-H*2417A*)	18,000 [5.3]	13,100 [3.8]	4,900 [1.4]	11.95	13.00	76	600 [283]	15,900 [4.7]	3.46	8,500 [2.5]	2.26	7.7
24	17AHS24HM (RCSA-H*2417A*) ①	23,800 [7.0]	17,300 [5.1]	6,500 [1.9]	12.00	13.00	74	800 [378]	20,800 [6.1]	3.40	11,000 [3.2]	2.06	7.7
	RCFA-H*2414A*	23,600 [6.9]	17,100 [5.0]	6,500 [1.9]	11.55	13.00	74	800 [378]	21,000 [6.2]	3.36	11,100 [3.3]	2.14	7.7
	RCFA-H*2417A*	23,600 [6.9]	17,100 [5.0]	6,500 [1.9]	11.55	13.00	74	800 [378]	21,000 [6.2]	3.36	11,100 [3.3]	2.14	7.7
	17AHBA24HM (RCHJ-24A1)	21,800 [6.4]	15,700 [4.6]	6,100 [1.8]	11.80	13.00	74	800 [378]	20,200 [5.9]	3.76	11,700 [3.4]	2.70	7.7
	(-)BHK-17 (RCHJ-24A1)	22,000 [6.4]	15,800 [4.6]	6,200 [1.8]	12.10	13.00	74	800 [378]	20,200 [5.9]	3.76	11,700 [3.4]	2.70	7.7
	(-)BHP-17 (RCHJ-24A1)	21,800 [6.4]	15,700 [4.6]	6,100 [1.8]	11.80	13.00	74	800 [378]	20,200 [5.9]	3.76	11,700 [3.4]	2.70	7.7
	17AHLA24HM (RCSA-H*2417A*)	24,200 [7.1]	17,650 [5.2]	6,550 [1.9]	13.25	14.00	74	775 [366]	20,200 [5.9]	3.64	10,400 [3.0]	2.30	8.2
	(-)HLA-HM2417 (RCSA-H*2417A*)	24,200 [7.1]	17,650 [5.2]	6,550 [1.9]	13.25	14.00	74	775 [366]	20,200 [5.9]	3.64	10,400 [3.0]	2.30	8.2
	(-)HSA-HM2417 (RCSA-H*2417A*)	23,800 [7.0]	17,300 [5.1]	6,500 [1.9]	12.00	13.00	74	800 [378]	20,800 [6.1]	3.40	11,000 [3.2]	2.06	7.7

① Highest sales volume tested combination required by D.O.E. test procedures.

[] Designates Metric Conversions

Performance Data ARI Standard Conditions (cont.)

Note: Only these combinations of indoor/outdoor units are approved and any other combinations should not be used.

Model Numbers		ARI Cooling Performance							ARI Htg. Performance (70°F [21.0°C] Indoor)				DOE Region IV HSPF
		80°F [26.5°C] DB/67°F [19.5°C] WB Indoor Air 95°F [35.0°C] DB Outdoor Air							Outdoor Air 47°F DB/43°F WB [8.5°C/6.0°C] DOE High Temp.		Outdoor Air 17°F DB/15°F WB [-8.5°C/-9.5°C] DOE Low Temp.		
Outdoor Unit 13PJA	Indoor Coil and/or Air Handler	Total Capacity BTU/H [kW]	Net Sens. BTU/H [kW]	Net Latent BTU/H [kW]	EER	SEER	Snd. Rate dB	Indoor CFM [L/s]	BTU/H [kW]	COP	BTU/H [kW]	COP	
30	17AHS30HM (RCSA-H*3617A*) ①	28,600 [8.4]	21,200 [6.2]	7,400 [2.2]	11.70	13.00	73	1,000 [472]	27,600 [8.1]	3.60	15,700 [4.6]	2.44	7.7
	RCFA-H*3617A*	28,400 [8.3]	21,000 [6.2]	7,400 [2.2]	11.25	13.00	73	1,000 [472]	27,800 [8.1]	3.52	16,200 [4.7]	2.36	7.7
	RCFA-H*3621A*	28,400 [8.3]	21,000 [6.2]	7,400 [2.2]	11.25	13.00	73	1,000 [472]	27,800 [8.1]	3.52	16,200 [4.7]	2.36	7.7
	21AHBA36HM (RCHJ-36A1)	28,000 [8.2]	20,100 [5.9]	7,900 [2.3]	12.90	14.00	73	1,050 [495]	26,400 [7.7]	3.78	13,800 [4.0]	2.48	8.2
	(-)BHK-21 (RCHJ-36A1)	27,800 [8.1]	19,700 [5.8]	8,100 [2.4]	12.90	14.00	73	1,000 [472]	26,000 [7.6]	3.98	13,400 [3.9]	2.78	8.2
	(-)BHP-21 (RCHJ-36A1)	28,000 [8.2]	20,100 [5.9]	7,900 [2.3]	12.90	14.00	73	1,050 [495]	26,400 [7.7]	3.78	13,800 [4.0]	2.48	8.2
	17AHLA36HM (RCSA-H*3617A*)	29,000 [8.5]	21,600 [6.3]	7,400 [2.2]	12.40	14.00	73	1,000 [472]	28,200 [8.3]	3.76	14,900 [4.4]	2.52	8.2
	(-)HLA-HM3617 (RCSA-H*3617A*)	29,000 [8.5]	21,600 [6.3]	7,400 [2.2]	12.40	14.00	73	1,000 [472]	28,200 [8.3]	3.76	14,900 [4.4]	2.52	8.2
	(-)HSA-HM3017 (RCSA-H*3617A*)	28,600 [8.4]	21,200 [6.2]	7,400 [2.2]	11.70	13.00	73	1,000 [472]	27,600 [8.1]	3.60	15,700 [4.6]	2.44	7.7
36	17AHS36HM (RCSA-H*3617A*) ①	35,400 [10.4]	25,900 [7.6]	9,500 [2.8]	11.55	13.00	75	1,200 [566]	36,600 [10.7]	3.50	21,200 [6.2]	2.44	7.7
	RCFA-H*3617A*	35,400 [10.4]	25,900 [7.6]	9,500 [2.8]	11.35	13.00	75	1,200 [566]	36,600 [10.7]	3.50	21,200 [6.2]	2.44	7.7
	RCFA-H*3621A*	35,400 [10.4]	25,900 [7.6]	9,500 [2.8]	11.35	13.00	75	1,200 [566]	36,600 [10.7]	3.50	21,200 [6.2]	2.44	7.7
	RCHJ-36A1	34,800 [10.2]	23,700 [6.9]	11,100 [3.3]	11.45	13.00	75	1,200 [566]	34,800 [10.2]	3.30	21,000 [6.2]	2.32	7.7
	21AHBA36HM (RCHJ-36A1)	35,800 [10.5]	24,400 [7.1]	11,400 [3.3]	12.55	14.00	75	1,225 [578]	33,800 [9.9]	3.56	20,000 [5.9]	2.54	8.2
	(-)BHK-21 (RCHJ-36A1)	35,800 [10.5]	24,400 [7.1]	11,400 [3.3]	12.55	14.00	75	1,200 [566]	33,800 [9.9]	3.56	20,000 [5.9]	2.54	8.2
	(-)BHP-21 (RCHJ-36A1)	35,800 [10.5]	24,400 [7.1]	11,400 [3.3]	12.55	14.00	75	1,225 [578]	33,800 [9.9]	3.56	20,000 [5.9]	2.54	8.2
	17AHLA36HM (RCSA-H*3617A*)	36,000 [10.5]	26,400 [7.7]	9,600 [2.8]	12.20	14.00	75	1,200 [566]	35,400 [10.4]	3.64	20,400 [6.0]	2.56	8.2
	(-)HLA-HM3617 (RCSA-H*3617A*)	36,000 [10.5]	26,400 [7.7]	9,600 [2.8]	12.20	14.00	75	1,200 [566]	35,400 [10.4]	3.64	20,400 [6.0]	2.56	8.2
	(-)HSA-HM3617 (RCSA-H*3617A*)	35,400 [10.4]	25,900 [7.6]	9,500 [2.8]	11.55	13.00	75	1,200 [566]	36,600 [10.7]	3.50	21,200 [6.2]	2.44	7.7
(-)HSA-HM3621 (RCSA-H*3621A*)	35,400 [10.4]	25,900 [7.6]	9,500 [2.8]	11.55	13.00	75	1,200 [566]	36,600 [10.7]	3.50	21,200 [6.2]	2.44	7.7	
42	21AHS42HM (RCSA-H*4821A*) ①	41,000 [12.0]	29,700 [8.7]	11,300 [3.3]	11.20	13.00	77	1,400 [661]	40,000 [11.7]	3.52	23,800 [7.0]	2.24	7.7
	RCFA-H*4821A*	41,000 [12.0]	29,700 [8.7]	11,300 [3.3]	11.30	13.00	77	1,400 [661]	40,000 [11.7]	3.54	23,800 [7.0]	2.28	7.7
	RCFA-H*4824A*	41,000 [12.0]	29,700 [8.7]	11,300 [3.3]	11.30	13.00	77	1,400 [661]	40,000 [11.7]	3.54	23,800 [7.0]	2.28	7.7
	24AHBA48HM (RCHJ-48A1)	39,000 [11.4]	28,450 [8.3]	10,550 [3.1]	11.60	13.50	77	1,400 [661]	39,500 [11.6]	3.52	24,200 [7.1]	2.42	7.7
	(-)BHK-24 (RCHJ-48A1)	38,500 [11.3]	27,950 [8.2]	10,550 [3.1]	11.50	13.50	77	1,400 [661]	39,500 [11.6]	3.50	24,200 [7.1]	2.40	7.7
	(-)BHP-24 (RCHJ-48A1)	39,000 [11.4]	28,450 [8.3]	10,550 [3.1]	11.60	13.50	77	1,400 [661]	39,500 [11.6]	3.52	24,200 [7.1]	2.42	7.7
	21AHLA48HM (RCSA-H*4821A*)	41,500 [12.2]	30,150 [8.8]	11,350 [3.3]	12.20	14.00	77	1,400 [661]	39,000 [11.4]	3.72	23,000 [6.7]	2.38	8.2
	(-)HLA-HM4821 (RCSA-H*4821A*)	41,500 [12.2]	30,150 [8.8]	11,350 [3.3]	12.20	14.00	77	1,400 [661]	39,000 [11.4]	3.72	23,000 [6.7]	2.38	8.2
	(-)HSA-HM4221 (RCSA-H*4821A*)	41,000 [12.0]	29,700 [8.7]	11,300 [3.3]	11.20	13.00	77	1,400 [661]	40,000 [11.7]	3.52	23,800 [7.0]	2.24	7.7

① Highest sales volume tested combination required by D.O.E. test procedures.

Performance Data ARI Standard Conditions (con't.)

Note: Only these combinations of indoor/outdoor units are approved and any other combinations should not be used.

Model Numbers		ARI Cooling Performance							ARI Htg. Performance (70°F [21.0°C] Indoor)				
		80°F [26.5°C] DB/67°F [19.5°C] WB Indoor Air 95°F [35.0°C] DB Outdoor Air							Outdoor Air 47°F DB/43°F WB [8.5°C/6.0°C] DOE High Temp.		Outdoor Air 17°F DB/15°F WB [-8.5°C/-9.5°C] DOE Low Temp.		DOE Region IV HSPF
Outdoor Unit 13PJA	Indoor Coil and/or Air Handler	Total Capacity BTU/H [kW]	Net Sens. BTU/H [kW]	Net Latent BTU/H [kW]	EER	SEER	Snd. Rate dB	Indoor CFM [L/s]	BTU/H [kW]	COP	BTU/H [kW]	COP	
48	21AHLA48HM (RCSA-H*4821A*) ①	47,500 [13.9]	34,850 [10.2]	12,650 [3.7]	11.50	13.00	77	1,525 [720]	44,500 [13.0]	3.56	28,000 [8.2]	2.50	7.7
	(-)HLA-HM4821 (RCSA-H*4821A*)	48,000 [14.1]	35,100 [10.3]	12,900 [3.8]	11.55	13.00	77	1,525 [720]	44,000 [12.9]	3.56	28,000 [8.2]	2.50	7.7
	24AHLA48HM (RCSA-H*4824A*)	48,000 [14.1]	35,250 [10.3]	12,750 [3.7]	11.65	13.50	77	1,625 [767]	44,500 [13.0]	3.58	28,000 [8.2]	2.50	7.7
	(-)HLA-HM4824 (RCSA-H*4824A*)	48,000 [14.1]	35,250 [10.3]	12,750 [3.7]	11.65	13.50	77	1,625 [767]	44,500 [13.0]	3.58	28,000 [8.2]	2.50	7.7
60	24AHLA60HM (RCSA-H*6024A*) ①	58,000 [17.0]	41,900 [12.3]	16,100 [4.7]	11.75	13.00	77	1,825 [861]	55,000 [16.1]	3.82	31,000 [9.1]	2.52	7.7
	RCFA-H*6024A*	57,000 [16.7]	40,900 [12.0]	16,100 [4.7]	11.20	13.00	77	1,825 [861]	55,500 [16.3]	3.68	31,800 [9.3]	2.34	7.7
	(-)HLA-HM6024 (RCSA-H*6024A*)	58,500 [17.1]	42,300 [12.4]	16,200 [4.7]	11.80	13.00	77	1,825 [861]	54,500 [16.0]	3.76	33,600 [9.8]	2.60	7.7

① Highest sales volume tested combination required by D.O.E. test procedures.

Electrical and Physical Data

Model Number 13PJA	ELECTRICAL							PHYSICAL						
	Phase Frequency (Hz) Voltage (Volts)	Compressor		Fan Motor Full Load Amperes (FLA)	Minimum Circuit Ampacity Amperes	Fuse or HACR Circuit Breaker		Outdoor Coil			Refrig. Per Circuit Oz. [g]	Weight		
		Rated Load Amperes (RLA)	Locked Rotor Amperes (LRA)			Minimum Amperes	Maximum Amperes	Face Area Sq. Ft. [m²]	No. Rows	CFM [L/s]		Net Lbs. [kg]	Shipping Lbs. [kg]	
18	1-60-208/230	9/9	41	0.6	12/12	15/15	20/20	11.06 [1.03]	1	1700 [802]	81 [2296]	142 [64.4]	150 [68.0]	
24	1-60-208/230	14.1/14.1	54	0.8	19/19	25/25	30/30	13.72 [1.27]	1	2370 [1118]	99 [2807]	180 [81.6]	190 [86.2]	
30	1-60-208/230	14.6/14.6	67	0.8	20/20	25/25	30/30	16.39 [1.52]	1	2800 [1321]	115 [3260]	210 [95.3]	222 [100.7]	
36	1-60-208/230	18/18	83	1.2	24/24	30/30	40/40	21.85 [2.03]	1	3575 [1687]	134 [3799]	224 [101.6]	236 [107.0]	
42	1-60-208/230	19.2/19.2	105	1.2	26/26	35/35	40/40	21.85 [2.03]	1	3575 [1687]	150 [4252]	214 [97.1]	226 [102.5]	
48	1-60-208/230	26.1/26.1	137	1.2	34/34	45/45	50/50	21.85 [2.03]	1	3575 [1687]	154 [4366]	220 [99.8]	232 [105.2]	
60	1-60-208/230	25.3/25.3	150	1.2	33/33	40/40	50/50	21.85 [2.03]	2	3365 [1588]	256 [7258]	283 [128.4]	295 [133.8]	

[] Designates Metric Conversions

BEFORE PURCHASING THIS APPLIANCE, READ IMPORTANT ENERGY COST AND EFFICIENCY INFORMATION AVAILABLE FROM YOUR RETAILER.

GENERAL TERMS OF LIMITED WARRANTY

ICECOSM will furnish a replacement for any part of this product which fails in normal use and service within the applicable periods stated, in accordance with the terms of the limited warranty.

Condenser Coil leaks caused by
factory defects Five (5) Years
Compressor Five (5) Years
Any Other Part..... Five (5) Years

For Complete Details of the Limited Warranty, Including Applicable Terms and Conditions, See Your Local Installer or visit www.ICECOHvac.com.

Unit Dimensions

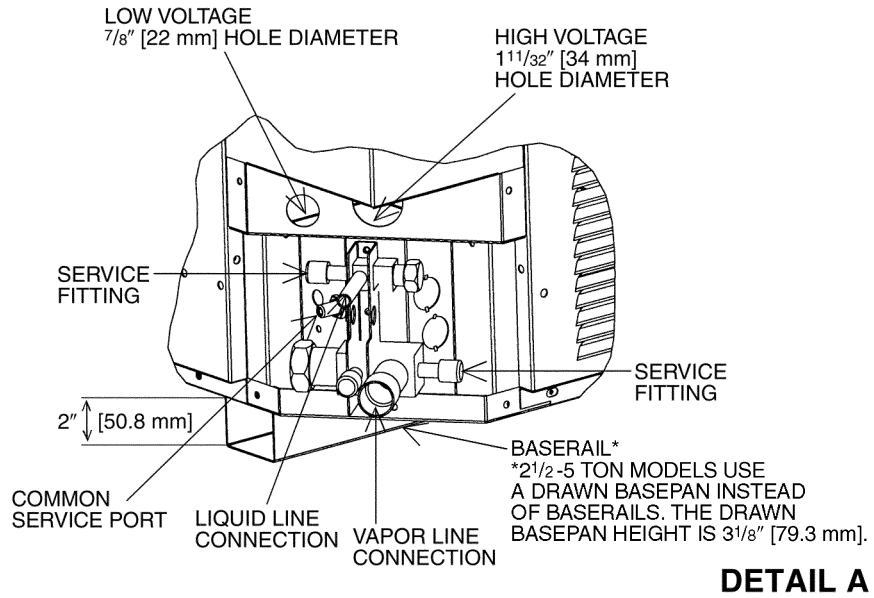
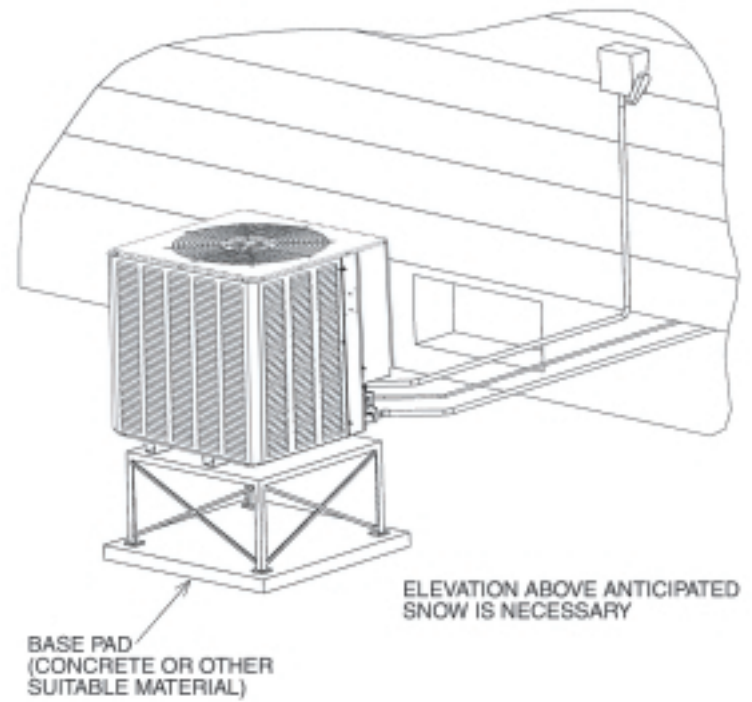
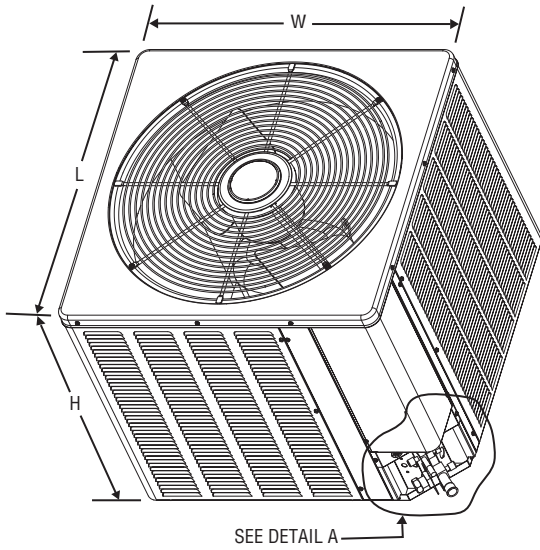

DETAIL A

Model Number 13PJA	Height "H" (Inches) [mm]	Length "L" (Inches) [mm]	Width "W" (Inches) [mm]
18	26 ¹ / ₄ [666.75]	23 ⁵ / ₈ [600.07]	23 ⁵ / ₈ [600.07]
24	26 ¹ / ₄ [666.75]	27 ⁵ / ₈ [701.67]	27 ⁵ / ₈ [701.67]
30	27 ³ / ₈ [695.33]	31 ⁵ / ₈ [803.27]	31 ⁵ / ₈ [803.27]
36/42/48/60	35 ³ / ₈ [898.53]	31 ⁵ / ₈ [803.27]	31 ⁵ / ₈ [803.27]

[] Designates Metric Conversions

Heat Pump Refrigerant Line Size Information

System Capacity	Liquid Line Connection Size (Inch I.D.) [mm]	Line Size (Inch O.D.) [mm]	Liquid Line Size (R-22) Outdoor Unit Above or Below Indoor Coil (Heat Pumps Only)					
			Total Equivalent Length—Feet [m]					
			25 [7.62]	50 [15.24]	75 [22.86]	100 [30.48]	125 [38.10]	150 [45.72]
			Maximum Vertical Separation—Feet [m]					
1 1/2 Ton	3/8" [9.53]	1/4 [6.35]	21 [6.40]	8 [2.44]	N/A	N/A	N/A	N/A
		5/16 [7.94]	25 [7.62]	27 [8.23]	24 [7.32]	21 [6.40]	17 [5.18]	14 [4.27]
		3/8* [9.53]	25 [7.62]	40 [12.19]	39 [11.89]	38 [11.58]	37 [11.28]	35 [10.67]
2 Ton	3/8" [9.53]	1/4 [6.35]	16 [4.88]	N/A	N/A	N/A	N/A	N/A
		5/16 [7.94]	25 [7.62]	26 [7.92]	21 [6.40]	15 [4.57]	10 [3.05]	5 [1.52]
		3/8* [9.53]	25 [7.62]	38 [11.58]	36 [10.97]	35 [10.67]	33 [10.06]	31 [9.45]
2 1/2 Ton	3/8" [9.53]	1/4 [6.35]	0	N/A	N/A	N/A	N/A	N/A
		5/16 [7.94]	25 [7.62]	17 [5.18]	8 [2.44]	0	N/A	N/A
		3/8* [9.53]	25 [7.62]	37 [11.28]	34 [10.36]	31 [9.45]	29 [8.84]	26 [7.92]
3 Ton	3/8" [9.53]	5/16 [7.94]	25 [7.62]	15 [4.57]	4 [1.22]	N/A	N/A	N/A
		3/8* [9.53]	25 [7.62]	30 [9.14]	26 [7.92]	23 [7.01]	19 [5.79]	16 [4.88]
3 1/2 Ton	3/8" [9.53]	5/16 [7.94]	25 [7.62]	17 [5.18]	2 [0.61]	N/A	N/A	N/A
		3/8* [9.53]	25 [7.62]	37 [11.28]	32 [9.75]	28 [8.53]	23 [7.01]	18 [5.49]
4 Ton	3/8" [9.53]	3/8* [9.53]	25 [7.62]	33 [10.06]	27 [8.23]	21 [6.40]	15 [4.57]	9 [2.74]
		1/2 [12.7]	25 [7.62]	43 [13.11]	42 [12.80]	40 [12.19]	39 [11.89]	38 [11.58]
5 Ton	3/8" [9.53]	3/8* [9.53]	25 [7.62]	25 [7.62]	17 [5.18]	8 [2.44]	0	N/A
		1/2 [12.7]	25 [7.62]	39 [11.89]	37 [11.28]	36 [10.97]	34 [10.36]	32 [9.75]

NOTES:
 *Standard line size
 N/A = Application not recommended.

Suction Line Length/Size versus Capacity Multiplier (R-22)								
Unit Size		1 1/2 Ton	2 Ton	2 1/2 Ton	3 Ton	3 1/2 Ton	4 Ton	5 Ton
Suction Line Connection Size		3/4" [19.05] I.D.			7/8" [22.23] I.D.			
Suction Line Run—Feet [m]		5/8" [15.88 mm] O.D. Opt. 3/4" [19.05 mm] O.D. Std.*	5/8" [15.88 mm] O.D. Opt. 3/4" [19.05 mm] O.D. Std.* 7/8" [22.23 mm] O.D. Opt.		3/4" [19.05 mm] O.D. Opt. 7/8" [22.23 mm] O.D. Std.*	3/4" [19.05 mm] O.D. Opt. 7/8" [22.23 mm] O.D. Std.* 1 1/8" [28.58 mm] O.D. Opt.	7/8" [22.23 mm] O.D. Opt.	1 1/8" [28.58 mm] O.D. Std.*
25' [7.62]	Optional	.99	.99	.98	.99	.99	.99	.99
	Standard	1.00	1.00	1.00	1.00	1.00	1.00	1.00
	Optional	—	1.00	1.00	—	1.00	—	—
50' [15.24]	Optional	.97	.96	.96	.98	.97	.98	.97
	Standard	.99	.99	.98	.99	.98	.99	.99
	Optional	—	.99	.99	—	1.00	—	—
100' [30.48]	Optional	.94	.92	.94	.95	.93	.95	.95
	Standard	.96	.96	.96	.96	.96	.98	.98
	Optional	—	.97	.97	—	.98	—	—
150' [45.72]	Optional	.90	.89	.92	.93	.92	.93	.93
	Standard	.93	.93	.93	.94	.94	.96	.96
	Optional	—	.95	.95	—	.96	—	—

NOTES: *Standard line size
 Using suction line larger than shown in chart will result in poor oil return and is not recommended.

[] Designates Metric Conversions

NOTES

Before proceeding with installation, refer to installation instructions packaged with each model, as well as complying with all Federal, State, Provincial, and Local codes, regulations, and practices.



"In keeping with its policy of continuous progress and product improvement, ICECO reserves the right to make changes without notice."